



DO NOT SCALE DRAWING

TOLERANCES (UNLESS NOTED)
 DECIMALS = ±inches/mm
 .X = ±.1 /2.54
 .XX = ±.03 /0.76
 .XXX = ±.010/0.25
 HOLES: ±.003-.002/+-.08-.05
 ANGLES: = ± 30°

DRAWN	Gus H. Elias	10/00
CHECKED	W.Ho	10/00
ENGINEER	Gus H. Elias	10/00
SCALE	NONE	

CONTROL DRAWING

TITLE
 Field Installation Diagram:
THZ-DH
 PC Prog. Smart HART Temp. X-mitter.
 Intrinsically Safe System
 For Hazardous 'Classified' Locations.

DRAWING NUMBER
100-100-58

REVISION
A

REVISED BY	DATE	BY	APPROVAL
INITIAL RELEASE	G.E.	10/00	CB

NOTICE RE PROPRIETARY INFORMATION: This drawing and the information contained herein are the proprietary property of Moore Industries-International, Inc. (MII) and should not be reproduced or disclosed to any third party without the written consent of an authorized officer of MII.

CERTIFIED PRODUCT
 This is a controlled 'Related' or 'Schedule' drawing. No modifications are permitted without the notification and final approval of the Q.A. Certification Engineer (related dwgs.) or the Certifying Agency (schedule dwgs.).

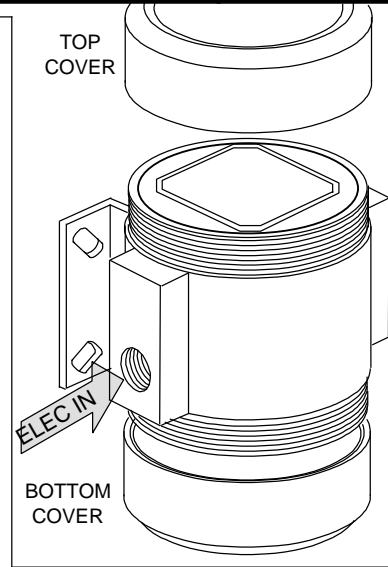
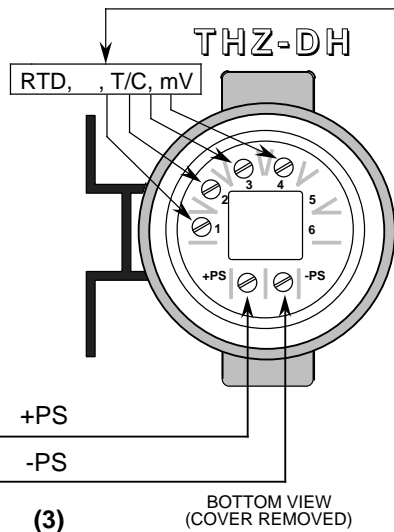
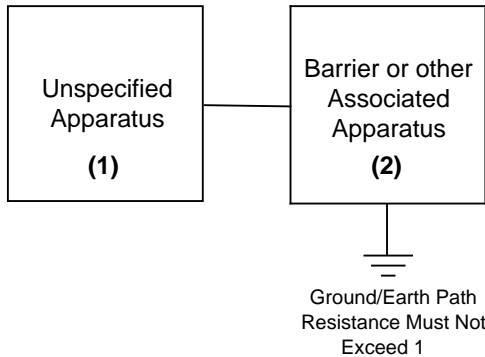

Entity Parameters (Power/Loop, +PS & -PS):

V_{max} or U_i	= 30 VDC
I_{max} or I_i	= 110 mA
P_{max} or P_i	= 0.825 W
C_i	= 13 nF
L_i	= 0 μH
L_o/R_o	= 43.1 μH/
C_a or C_o	$C_i + C_{cable}$
L_a or L_o	$L_i + L_{cable}$
V_{oc} or V_t	V_{oc} or V_t
I_{sc} or I_t	I_{sc} or I_t

RTD, T/C, mV:

C_a or C_o	= 48 μF
L_a or L_o	= 0.34 mH
V_{oc} or V_t	= 5.355 V
I_{sc} or I_t	= 314 mA
P_o	= 0.825 W

Input device must be 'Agency' approved per application area. (CSA, EECs, FM, ISSEP, LCIE, SIRA, SAA, TUV, etc...).

Hazardous (Classified) Locations - FMR (US NEC-500):
 Intrinsically Safe: Class I,II,III; Div. 1; Groups A-G.
 Non-Incendive: Class I, Div. 2, Groups A-D.
 Class II, Div. 2, Groups F & G and Class III, Div. 2.
 US NEC-505: Class I, Zone 0, AEx ia IIC, T4 @ 60°C

T. Code: T4A @ 40°C & T4 @ 60°C
 Maximum Operating Ambient Temperature

Hazardous (Classified) Locations/Areas:
CSA International
 Intrinsically Safe: Class I, Div. 1 & 2, Groups A-D.
 Class II, Div. 1, Groups E, F & G.
 Class II, Div. 2, Groups F & G. Class III.
CENELEC/ATEX
 Intrinsically Safe: Ex II 1G EEx ia IIC, T4 @ 60°C

Dual-Compartment Field-Mount Enclosure Protection: IP66 & NEMA 4X

Notes:

- (1) Apparatus which is unspecified except that it **must not** be supplied from, or contain under normal or abnormal conditions a source of potential with respect to earth in excess of 250 VRMS or 250 VDC which is considered to be the Safe Area's maximum voltage.
- (2) The Barrier or other Associated Apparatus **must** be approved by the "specific" (CSA/EECS/FM/LCIE/SAA/SIRA/TUV, etc...) certifying agency for I.S. connections in: "Class I-III, Division 1, Groups A-G" or equivalent Zone classifications for Hazardous 'Classified' Locations. The output voltage (**Voc, Vt or Vo**) **must not** exceed 30 VDC & the output current (**Isc, It or Io**) **must not** exceed 110 mA. Also, it **must** be installed per the manufacturer's guidelines. *A Shunt Zener Barrier is NOT required for Non-Incendive (or Class I, Division 2 or Type N) installations.*
- (3) The combined Capacitance and Inductance of the inter-connecting cables and the PC Prog. Transmitter **must not** exceed the values indicated on the Associated Apparatus.
- 4- For FM applications, installation **must** be in accordance to 'ANSI/ISA-RP12.6' (Installation of I.S. Systems for Hazardous 'Classified' Locations) and the National Electric Code 'ANSI/NFPA 70'. Also, a dust-tight conduit seal **must** be used when installed in Class II and Class III environments. For CSA applications, adhere to the 'Canadian Electric Code C22.1' most current publication on I.S. installation guidelines. For CENELEC/ATEX applications, adhere to 'EN 60079-14:1997' or any equivalent, most current and pertaining publication on I.S. installation guidelines.
- 5- **Warning:** Substitution of components may impair the unit's Intrinsic Safety and/or Non-Incendivity. **DO NOT** open the unit when either energized or when an explosive gas/dust atmosphere is present. Disconnect power before servicing. Also read, understand and adhere to the manufacturer's installation and operating procedures.