



<b>DO NOT SCALE DRAWING</b>	
TOLERANCES (UNLESS NOTED)	DRAWN C. Whan
DECIMALS = 1/16 inch/mm	CHECKED CAM
X ±.1 / 2.54	0. Denton
.XX ±.01 / 0.25	SCALE NONE
XXX ±.005/0.125	
HOLES ±.003/0.080	
ANGLES ±.1/2°	

CATEGORY	CONTROL DRAWING
TITLE	RMA100/RMA100C I.S. INSTALLATION DIAGRAM, ATEX

DRAWING NUMBER	RMA100-001 SHEET 1 OF 3	REVISION	B
REVISED BY	ECO 15591	DATE	10/09
BY	CW	APPROVAL	<i>CR</i>

NOTICE RE PROPRIETARY INFORMATION: This drawing and the information contained herein are the proprietary property of Moore Industries International, Inc. (MII) and should not be reproduced or disclosed to any third party without the written consent of an authorized officer of MII.

WHERE ENGLISH IS NOT A LANGUAGE OF THE COUNTRY IN WHICH THE EQUIPMENT IS BEING USED, PLEASE APPLY TO MooreHawke FOR A SUITABLE TRANSLATION.

NON-HAZARDOUS AREA HAZARDOUS AREA

ZONES 0, 1 and 2  
GAS GROUP IIA/IB

**EEx Ia IIB TRUNK CONNECTIONS**  
 Uo = 18.9V  
 Io = 830.04mA  
 Po = 3.93W  
 Co = 1.6uF (IIB) 6.39uF (IIA)  
 Lo = 0.206mH (IIB) 0.412mH (IIA)

**EEx Ia IIC SPUR CONNECTIONS (ENTITY)**  
 Uo = 18.9V  
 Io = 249.9mA  
 Po = 1.181W  
 Co = 262nF (IIC) 1.6uF (IIB) 6.39uF (IIA)  
 Lo = 0.150mH (IIC) 0.206mH (IIB) 0.412mH (IIA)  
 Lo/Ro = 30uH/ohm (IIC) 36uH/ohm (IIB)  
 7ZuH/ohm (IIA)

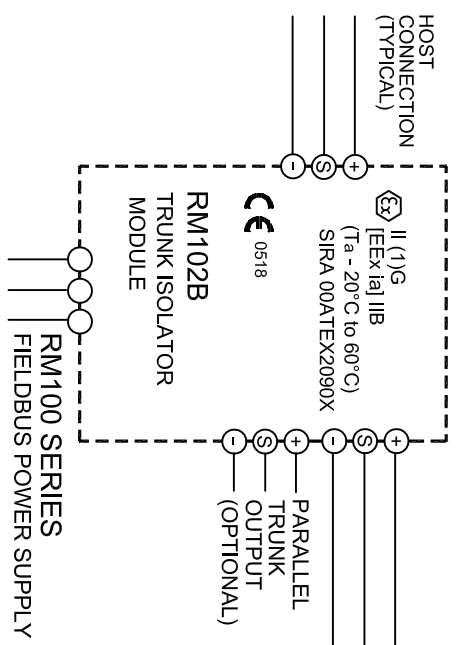

RMA100-DIN

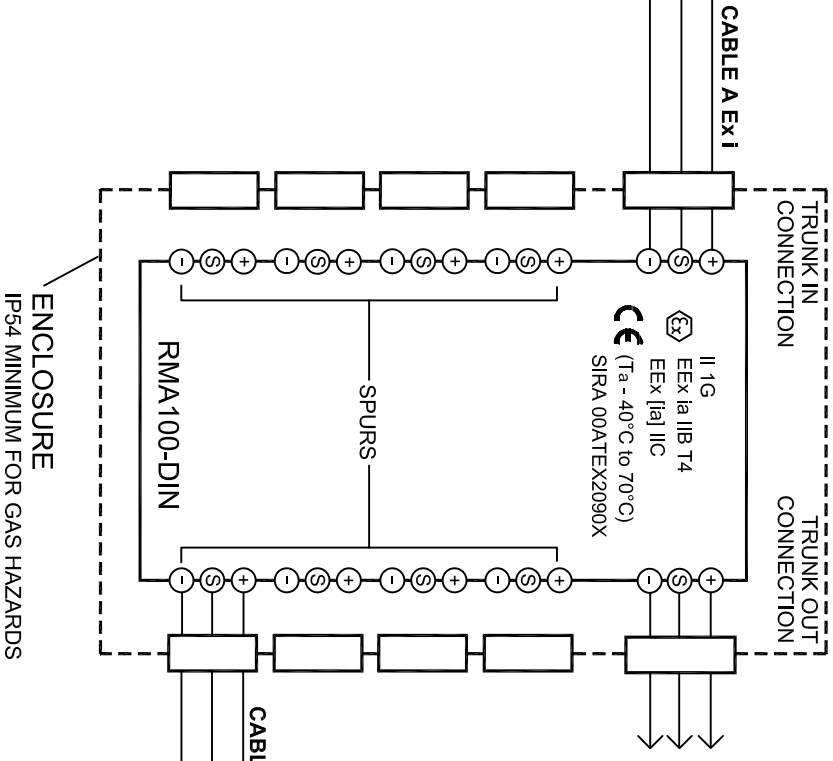

Capacitance limit is per spur cable and per trunk cable (independently assessed).  
 Inductance limit is for total cable (spurs plus trunk).  
 Lo/Ro is the total maximum allowable inductance to maximum resistance (per trunk plus spur).  
 The Lo/Ro values are appropriate for Hazardous Location Apparatus with the following permitted values of LI and CI. The values vary depending upon the group of the hazardous location:  
 Group IIC LI = 0, CI = 2.62 nF  
 Group IIB LI = 0, CI = 16 nF  
 Group IIA LI = 0, CI = 63.9 nF

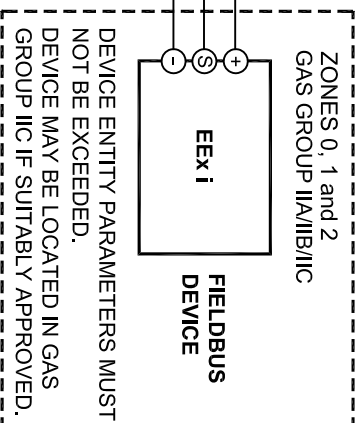

ENCLOSURE  
IP54 MINIMUM FOR GAS HAZARDS

INSTALLATION MAY ONLY BE CARRIED OUT BY SUITABLY TRAINED PERSONNEL AND IN ACCORDANCE WITH NATIONAL WIRING REGULATIONS OR CODES OF PRACTICE. USER REPAIR OF RMA100 UNIT IS NOT POSSIBLE.

**Certified Product**  
 This is a controlled 'Related' or 'Schedule' drawing. No modifications are permitted without the notification and final approval of the Certification Engineer (related dwgs.) or the Certifying Agency (schedule dwgs.).



# DO NOT SCALE DRAWING

TOLERANCES (UNLESS NOTED)	DRAWN	C. Whan	1/06
DECIMALS = X = ±.1 / 2.54 XX = ±.01 / 0.25 XXX = ±.005 / 0.125	CHECKED	See Sht.1	
HOLES = ±.003 / 0.080	SCALE	NONE	
ANGLES = ±1/2°			

CATEGORY CONTROL DRAWING

## TITLE

# RMA100/RMA100C

## I.S. INSTALLATION

### DIAGRAM, ATEX

DRAWING NUMBER RMA100-001 SHEET 2 OF 3

REVISION B

REVISED BY SEE SHEET 1 DATE BY APPROVAL

NOTICE RE PROPRIETARY INFORMATION: This drawing and the information contained herein are the proprietary property of Moore Industries International, Inc. (MII) and should not be reproduced or disclosed to any third party without the written consent of an authorized officer of MII.

### NON-HAZARDOUS AREA

INSTALLATION MAY ONLY BE CARRIED OUT BY SUITABLY TRAINED PERSONNEL AND IN ACCORDANCE WITH NATIONAL WIRING REGULATIONS OR CODES OF PRACTICE. USER REPAIR OF RMA100C UNIT IS NOT POSSIBLE.

WHERE ENGLISH IS NOT A LANGUAGE OF THE COUNTRY IN WHICH THE EQUIPMENT IS BEING USED, PLEASE APPLY TO MooreHawke FOR A SUITABLE TRANSLATION.

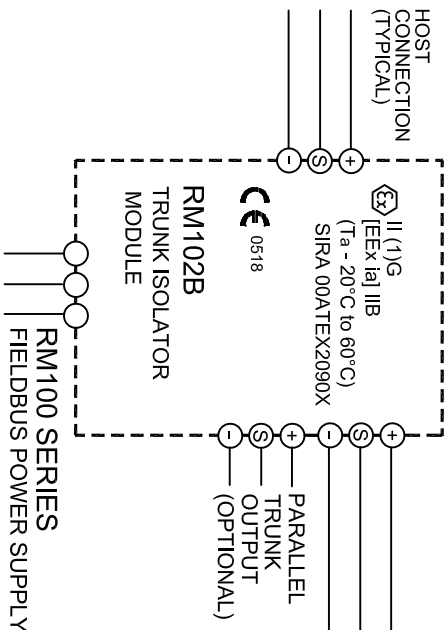

### HAZARDOUS AREA

ZONES 0, 1 and 2  
GAS GROUP IIA/IIB

**EEx ia IIB TRUNK CONNECTIONS**  
 $U_0 = 18.9V$   
 $I_0 = 830.04mA$   
 $P_0 = 3.93W$   
 $C_0 = 1.6\mu F$  (IIB) 6.39 $\mu F$  (IIA)  
 $L_0 = 0.206mH$  (IIB) 0.412mH (IIA)

### RMA100C-DIN

**EEx ia IIB TRUNK CONNECTIONS**

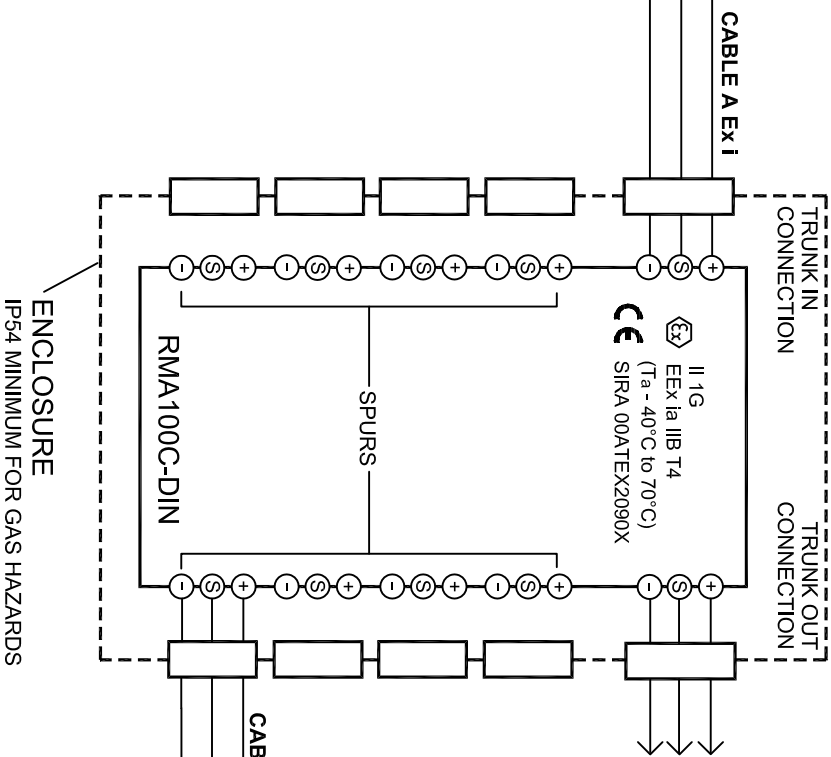

**EEx ia IIC SPUR CONNECTIONS (ENTITY)**  
 $U_0 = 17.5V$   
 $I_0 = 249.9mA$   
 $P_0 = 1.18W$   
 $C_0 = 262nF$  (IIC) 1.6 $\mu F$  (IIB) 6.39 $\mu F$  (IIA)  
 $L_0 = 0.150mH$  (IIC) 0.206mH (IIB) 0.412mH (IIA)  
 $Lo/Lo = 30\mu H/\Omega m$  (IIC) 36 $\mu H/\Omega m$  (IIB)  
 $7Z\mu H/\Omega m$  (IIA)

Capacitance limit is per spur cable and per trunk cable (independently assessed). Inductance limit is for total cable (spurs plus trunk).  
 $Lo/R_0$  is the total maximum allowable inductance to maximum resistance (per trunk plus spur).  
 The  $Lo/R_0$  values are appropriate for Hazardous Location Apparatus with the following permitted values of  $L_I$  and  $C_I$ . The values vary depending upon the group of the hazardous location:  
 Group IIC  $L_I = 0, C_I = 2.62 nF$   
 Group IIB  $L_I = 0, C_I = 16 nF$   
 Group IIA  $L_I = 0, C_I = 63.9 nF$

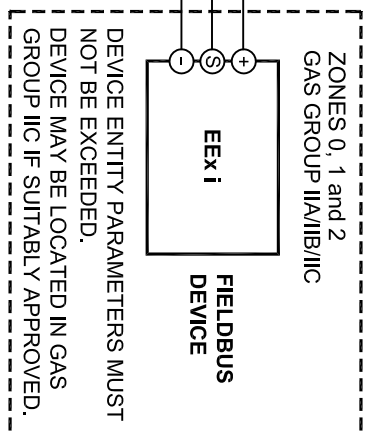

ZONES 0, 1 and 2  
GAS GROUP IIA/IIB/IIC  
FIELDBUS DEVICE  
EEx i  
DEVICE ENTITY PARAMETERS MUST NOT BE EXCEEDED.  
DEVICE MAY BE LOCATED IN GAS GROUP IIC IF SUITABLY APPROVED.

ENCLOSURE  
IP54 MINIMUM FOR GAS HAZARDS

### Certified Product

This is a controlled 'Related' or 'Schedule' drawing. No modifications are permitted without the notification and final approval of the Certifying Engineer (related dwgs.) or the Certifying Agency (schedule dwgs.)

### Cable Parameters (FISCO Application)

The combination of an RM100-series rack (Sira 00ATEX2090X) together with an RMA100C Device Coupler is suitable for use in a FISCO system in accordance with EN 60079-27:2006. For FISCO installations, the cable from the Trunk Isolator Module to the Device Coupler is "Cable A". The cable from the RMA100C Device Coupler to the downstream field device(s) is "Cable B". "Cable B" shall comply with the following parameters: a) Loop resistance (Rc): 15 W/km to 150 W/km; b) Loop inductance (Lc): 0.4 mH/km to 1 mH/km; c) Capacitance (Cc): 45nF/km to 200 nF/km.



# DO NOT SCALE DRAWING

TOLERANCES (UNLESS NOTED)	DRAWN	C. Whan	1/06
DECIMALS = $\pm$ inch/mm	CHECKED	See Sht.1	
X = $\pm$ .1 / 2.54		See Sht.1	
.XX = $\pm$ .01 / 0.25			
.XXX = $\pm$ .005 / 0.125			
HOLES = $\pm$ .003 / 0.080	SCALE	NONE	
ANGLES = $\pm$ .1/2°			

CATEGORY CONTROL DRAWING

## RMA100/RMA100C I.S. INSTALLATION DIAGRAM, ATEX

DRAWING NUMBER

RMA100-001 SHEET 3 OF 3

REVISION **B**

REVISED BY

SEE SHEET 1

DATE

BY

APPROVAL

NOTICE RE PROPRIETARY INFORMATION: This drawing and the information contained herein are the proprietary property of Moore Industries International, Inc. (MII) and should not be reproduced or disclosed to any third party without the written consent of an authorized officer of MII.

### NON-HAZARDOUS AREA

INSTALLATION MAY ONLY BE CARRIED OUT BY SUITABLY TRAINED PERSONNEL AND IN ACCORDANCE WITH NATIONAL WIRING REGULATIONS OR CODES OF PRACTICE. USER REPAIR OF RMA100C UNIT IS NOT POSSIBLE.

WHERE ENGLISH IS NOT A LANGUAGE OF THE COUNTRY IN WHICH THE EQUIPMENT IS BEING USED, PLEASE APPLY TO Moorehawké FOR A SUITABLE TRANSLATION.

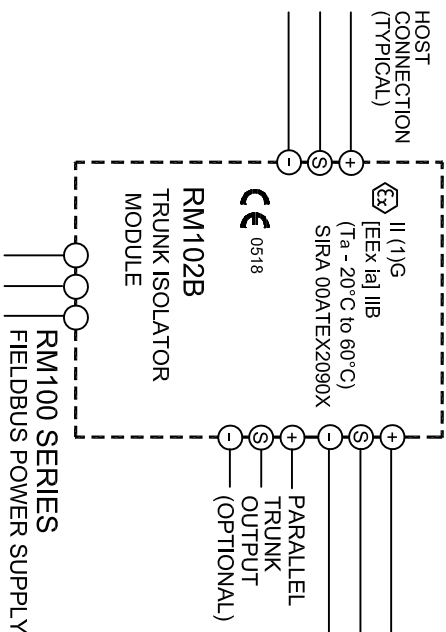

This is a controlled 'Related' or 'Schedule' drawing. No modifications are permitted without the notification and final approval of the Certification Engineer (related dwgs.) or the Certifying Agency (schedule dwgs.)

#### Certified Product

### Cable Parameters (FISCO Application)

The combination of an RM100-series rack (Sira 00ATEX2090X) together with an RMA100C Device Coupler is suitable for use in a FISCO system in accordance with EN 60079-27:2006. For FISCO installations, the cable from the Trunk Isolator Module to the Device Coupler is "Cable A". The cable from the RMA100C Device Coupler to the downstream field device(s) is "Cable B". "Cable B" shall comply with the following parameters: a) Loop resistance (Rc): 15 W/km to 150 W/km; b) Loop inductance (Lc): 0.4 mH/km to 1 mH/km; c) Capacitance (Cc): 45nF/km to 200 nF/km.

### HAZARDOUS AREA

ZONES 1 and 2  
GAS GROUP IIC

EEx e IIC TRUNK CONNECTIONS: 18.9V

### RMA100C-DIN

#### EEx e IIC TRUNK CONNECTIONS

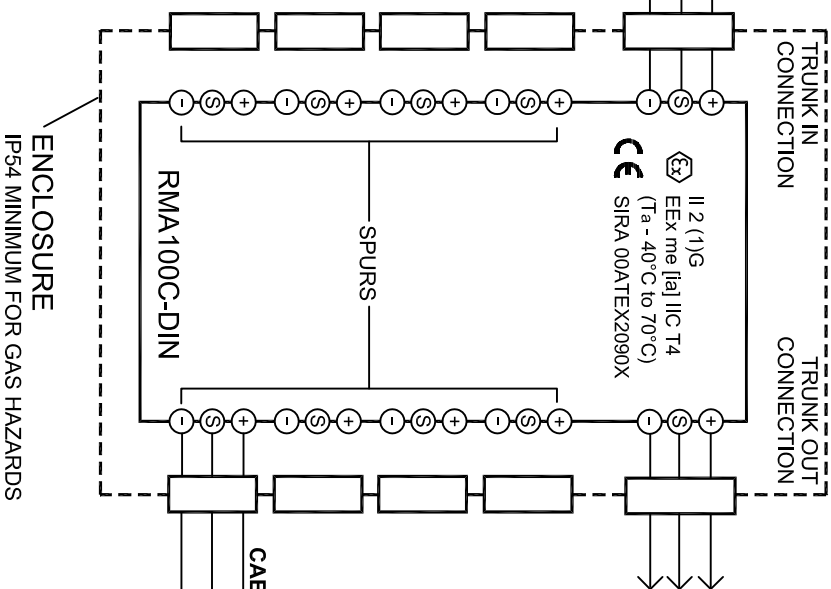

**EEx ia IIC SPUR CONNECTIONS (ENTITY)**

Uo = 17.5V  
Io = 249.9mA  
Po = 1.18W  
Co = 262nF (IIC) 1.6uF (IIB) 6.39uF (IIA)  
Lo = 0.150mH (IIC) 0.206mH (IIB) 0.412mH (IIA)  
Lo/Ro = 30uH/ohm (IIC) 36uH/ohm (IIB) 72uH/ohm (IIA)

Capacitance limit is per spur cable and per trunk cable (independently assessed). Inductance limit is for total cable (spurs plus trunk). Lo/Ro is the total maximum allowable inductance to maximum resistance (per trunk plus spur). The Lo/Ro values are appropriate for Hazardous Location Apparatus with the following permitted values of LI and CI. The values vary depending upon the group of the hazardous location:

Group IIC	LI = 0, CI = 2.62 nF
Group IIB	LI = 0, CI = 16 nF
Group IIA	LI = 0, CI = 63.9 nF

ZONES 0, 1 and 2  
GAS GROUP IIC

EEx i

FIELDBUS DEVICE

DEVICE ENTITY PARAMETERS MUST NOT BE EXCEEDED.  
DEVICE MAY BE LOCATED IN ZONE 0 IF SUITABLY APPROVED.