

NOW with MODBUS®

Description

Substantially reduce the cost of transmitting process signals with Moore Industries' unique problem solver, the CCS® Cable Concentrator System®. The industry-first CCS provides money-saving solutions for both monitoring and control applications.

Data Acquisition—The CCS collects any combination of up to 496 analog and/or digital signals from dispersed devices (transmitters, transducers, contact closures, etc.). It digitizes and concentrates the signals on to an RS-485 communication link, and sends the data miles between locations.

Control—With the CCS, you can transmit control signals long distances on a single data link to valves, pumps, motors, and other devices that require precise on/off or proportional control.



Featuring a compact DIN-style rail-mount housing, an integral digital display, and handy on-board configuration controls, the CCS is highly flexible, yet easy to use.

Figure 1. The CCS reduces the cost of transmitting multiple signals long distances by eliminating the need for point-to-point wiring. The more signals you have, the greater your savings.*

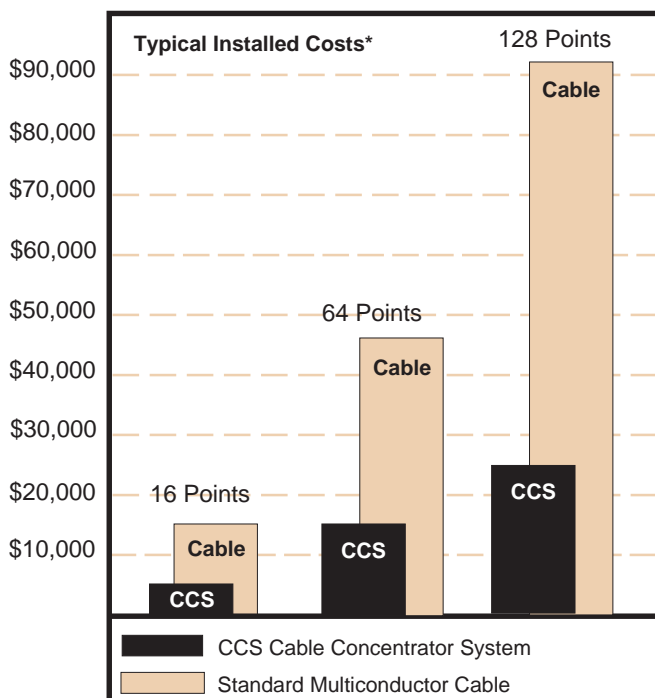

* Typical installed costs shown are for a Peer-to-Peer System, and the number of signal points indicated transmitted one mile at typical industry costs (U.S. dollars). *Standard Multiconductor Cable* values do not include conduit, wire trays, and other material costs or the labor costs associated with their installation. If these are required, savings realized from the CCS may be substantially greater.

Features

- **Configurable I/O Options.** Available modules accommodate analog (4-20mA, 1-5V, etc.), discrete, and relay process signals.
- **On-Site Programming and Calibration.** The CCS sets up and calibrates quickly and easily with on-board controls and prompts on its integral LCD.
- **MODBUS RTU Communication.** For Peer-to-Host Systems, this standard RS-485 protocol provides trouble-free interface with MMI software packages, PC, PLC, and DCS systems, and with other networkable instrumentation (-MBR option required).
- **Automatic Communication Restoration.** Without manual intervention, the CCS restores data transmission once the source of the communication failure is removed.
- **Stops Ground Loops.** Complete input/output/power isolation protects signals from degradation caused by ground loops and other electrical transients.
- **Transmit Any Distance, Over Any Terrain.** Use a twisted wire pair, fiber optic, radio link, or telephone modem data link to overcome rugged, long-distance, normally impassable, and hazardous environments.

Simple User Interface

Our CCS Cable Concentrator System is a favorite among plant personnel because it is highly flexible, yet simple to understand and use. If you want versatile cable concentrating without complicated set up, special tools, elaborate training, hand-helds, or dedicated configuration software, the CCS is your answer.

On-Board Programming

With the CCS, you'll be up and running fast. Selection of all input, output, and operational requirements are performed with on-board controls. Parameters that fre-

quently change, such as zero and span settings, are set using the front panel keyboard. Prompts on the module's integral front panel display guide you through configuration and calibration.

Local Process Indication

Unlike "blind" field modules, the CCS features a large, easy-to-read LCD. In addition to facilitating on-site programming, you can inspect the process status of any of the CCS's input or output channels with a push of a button. The display also shows problem-specific error messages to speed setup and troubleshooting.

Figure 2. Featuring on-board controls and an integral LCD, the CCS sets up in minutes without a hand-held, special tools, or training.

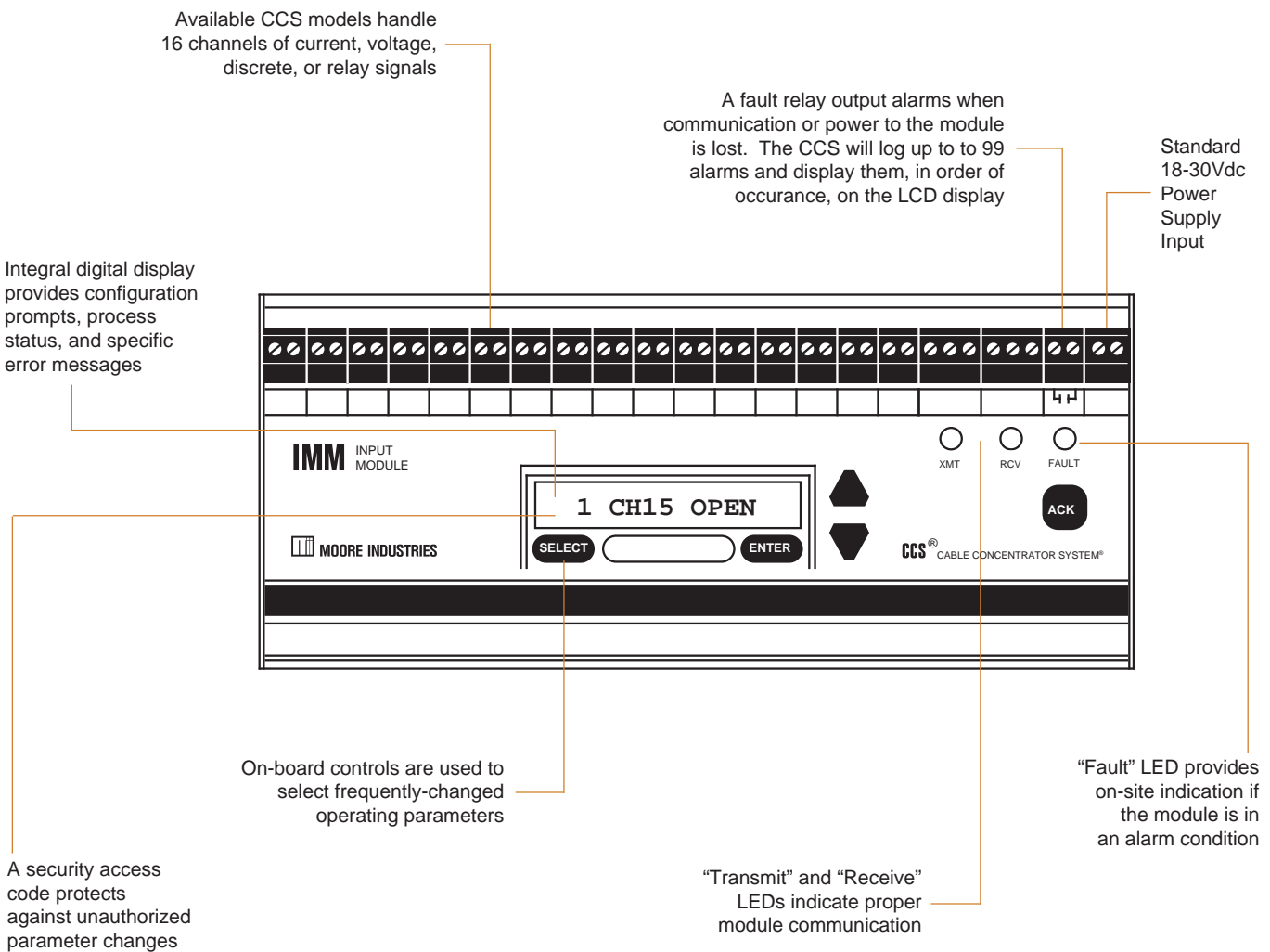
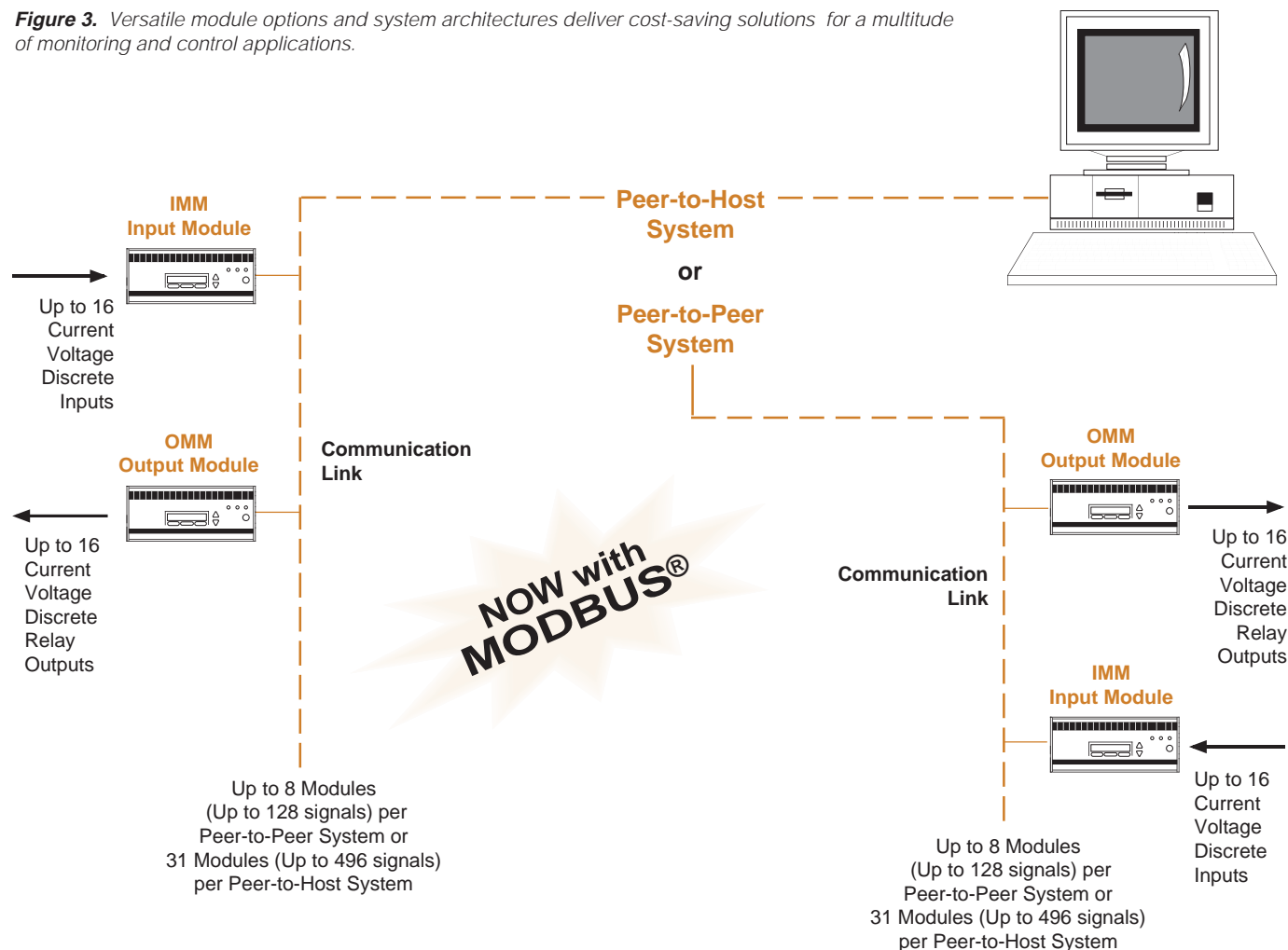

Figure 3. Versatile module options and system architectures deliver cost-saving solutions for a multitude of monitoring and control applications.



Save 70% per Installation

The CCS saves an average of 70% per installation when used in place of hard-wired schemes. Concentrate just a few, or hundreds of process signals, on to a single communication link. You'll save thousands on cable, conduit, connection, and wire tray costs. The CCS also simplifies overall system design, installation, and maintenance.

Module Types

Input (IMM) Modules—Each IMM module collects up to 16 process signals. It digitizes the data and sends it across the data link to a matching CCS OMM module or to a computer-based system. Available IMM modules handle current, voltage, and discrete signals (see Table 1 on page 11 for descriptions of available input types).

Output (OMM) Modules—Each 16-channel OMM module accepts digitized data sent over the data link from a matching IMM or from a computer-based host. It “expands” the digitized data and outputs current, voltage, discrete, or relay signals (see Table 1 on page 11 for descriptions of available output types).

System Architectures

A **Peer-to-Peer System** is used when multiple analog and discrete signals need to be collected, multiplexed so they can be economically transmitted long distances, and then returned to individual analog or discrete signals for readout (see Peer-to-Peer Systems on pages 4–5).

A **Peer-to-Host System** is a cost-effective strategy when distributed front end hardware is needed for a computer, DCS, or PLC-based system (see Peer-to-Host Systems on pages 6–7).

Peer-to-Peer Systems

In this architecture, CCS modules are arranged in pairs. For every module situated on one end of the communication link, there is a corresponding module on the opposite end of the link.

Monitor and Control

For data acquisition, the system collects signals from analog and digital devices like transmitters, transducers, relays, etc. It concentrates the signals, and sends the data to a matching module on the opposite side of the link.

For control, multiple signals can be digitized by the CCS in the control room, and sent over the data link to a matching module in the field. The field module converts the signals back to analog or discrete form for proportional or on/off control.

System Architecture

A Peer-to-Peer System, in its most simplest form, consists of one Input (IMM) Module and one Output (OMM) Module connected by a communication link (such as 24AWG telephone wire). This configuration allows up to 16 points to be monitored/controlled. To serve more elaborate data collection requirements, up to eight pairs of modules (see Figure 4) can be connected in a multidrop arrangement to handle up to 128 monitoring and control points (8 modules x 16 points per module = 128 points).

When multiple pairs of modules are used, one of the IMMs is configured as the "Master Controller". The remaining modules are designated as "Slaves". Once in operation, the "Master" IMM activates system communications and commands each module in the system to begin sending data to its corresponding OMM. The most recent digitized value collected on each IMM

Figure 4. A Peer-to-Peer System can be used to economically transmit any mix of up to 128 current, voltage, discrete, and/or relay signals long distances between remote locations.

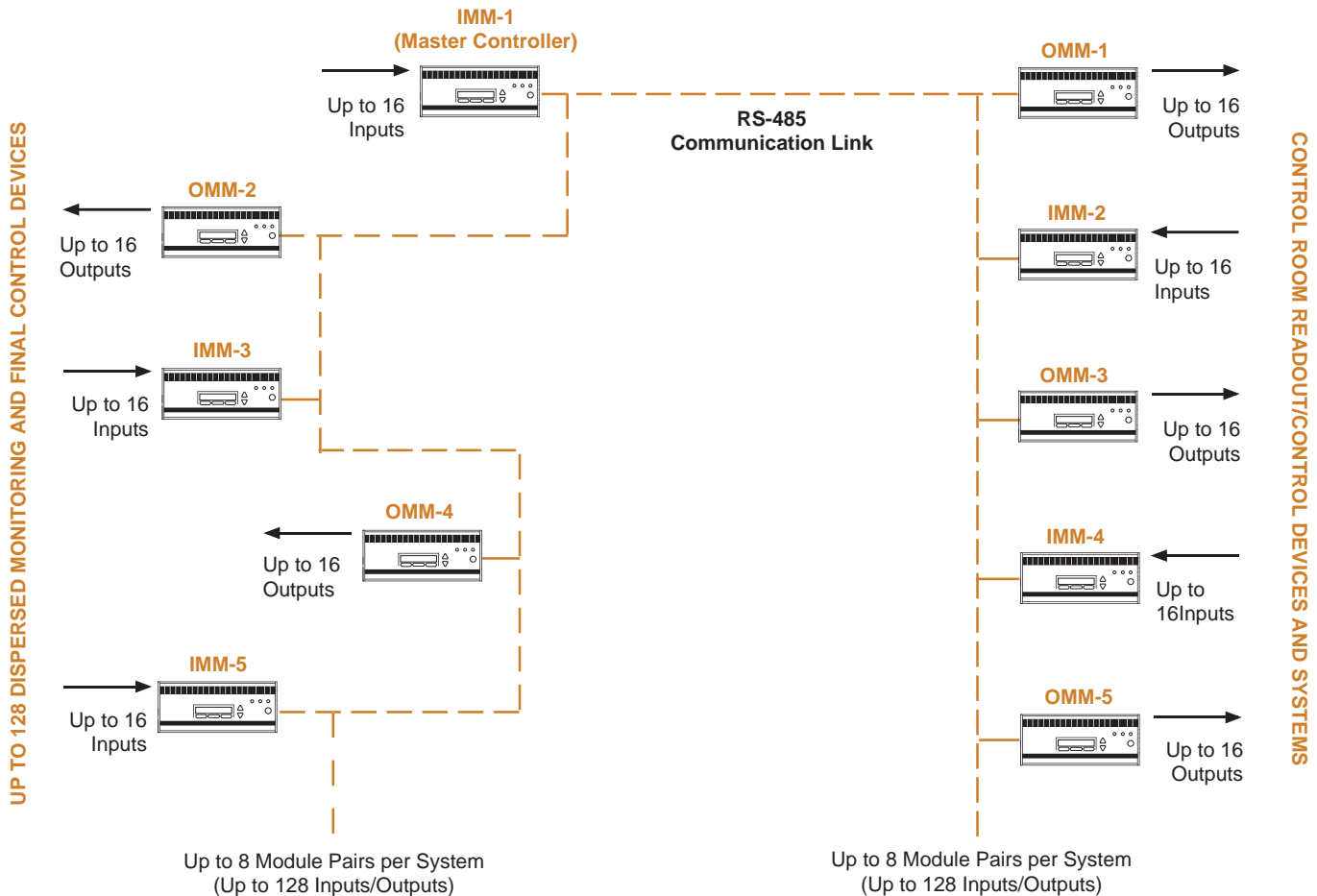
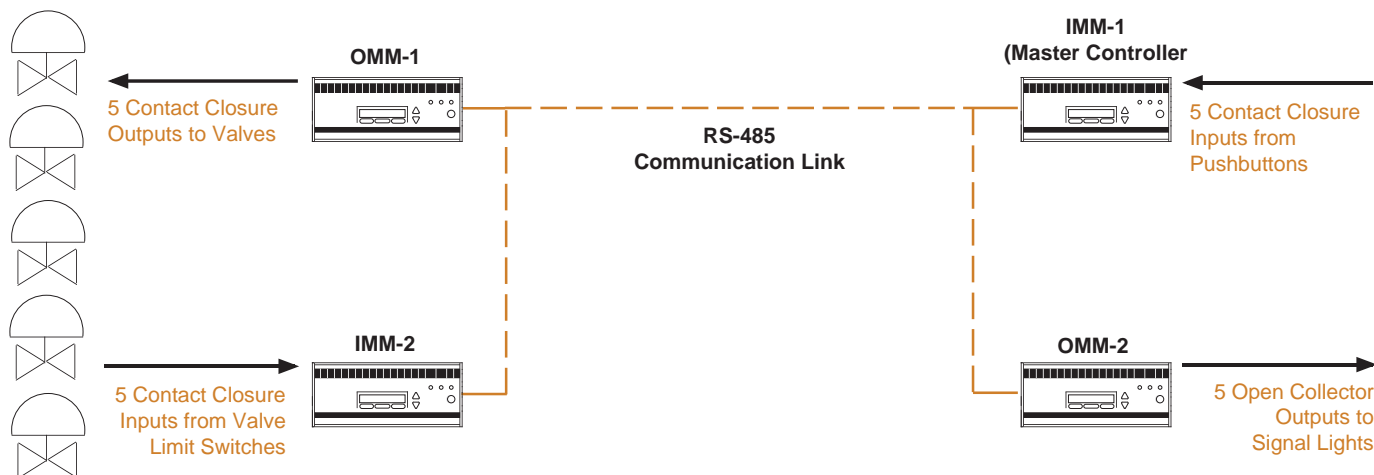

Figure 5. Using mixes of input and output modules on both sides of the communication link provides for applications such as simultaneous monitor and control of motor operated valves from a remote location.



point is then transmitted at least once per second along the communication link.

The system will accommodate a total communication link length of up to two miles, or an unlimited length if signal repeaters, modems, or radio transceivers are used (the CCS has integral selectable modem-ready firmware). The system's OMMs monitor the transmission line, and each OMM accepts only the data addressed to it by its matching IMM.

Once received, the transmitted data is converted back to its original form or to whatever signal format the user has selected during configuration (see Signal Inputs and Outputs in the "Specifications" section).

Modular Design and Expansion

To provide maximum flexibility and expandability, the CCS Cable Concentrator System's modular design allows any combination (see Table 1 on page 11) of IMM and OMM Module pairs to be mounted in any order along the length of the communication link.

One possibility is to have all Input Modules located in field locations and all Output Modules located in the control room; another is to have a cross-location of each type of module in both areas for communications in both directions on the communication link (see Figure 5).

CCS module pairs, up to the 8 pair per system maximum, may be added to a system at any time to accommodate system upgrades.

Signal Conversion & Isolation

The CCS converts and isolates signals, eliminating the need for separate signal isolators, converters and conditioners.

The Universal (U) CCS modules will accept voltage inputs at the IMM and convert them to current outputs—or vice versa—at the OMM (e.g., 0-10V in, 4-20mA out). The system will also accept any configurable discrete signals and convert—or even invert—they to any other configurable discrete signal (e.g., TTL in, Contact Closure out; HIGH in, LOW out).

Complete isolation between inputs/outputs, power and the COMM link protects signals from being degraded by electrical interference.

Figure 6. The CCS can be used to isolate and convert multiple process signals.

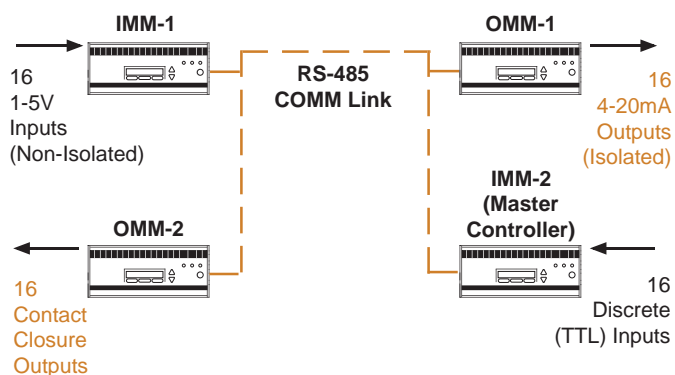
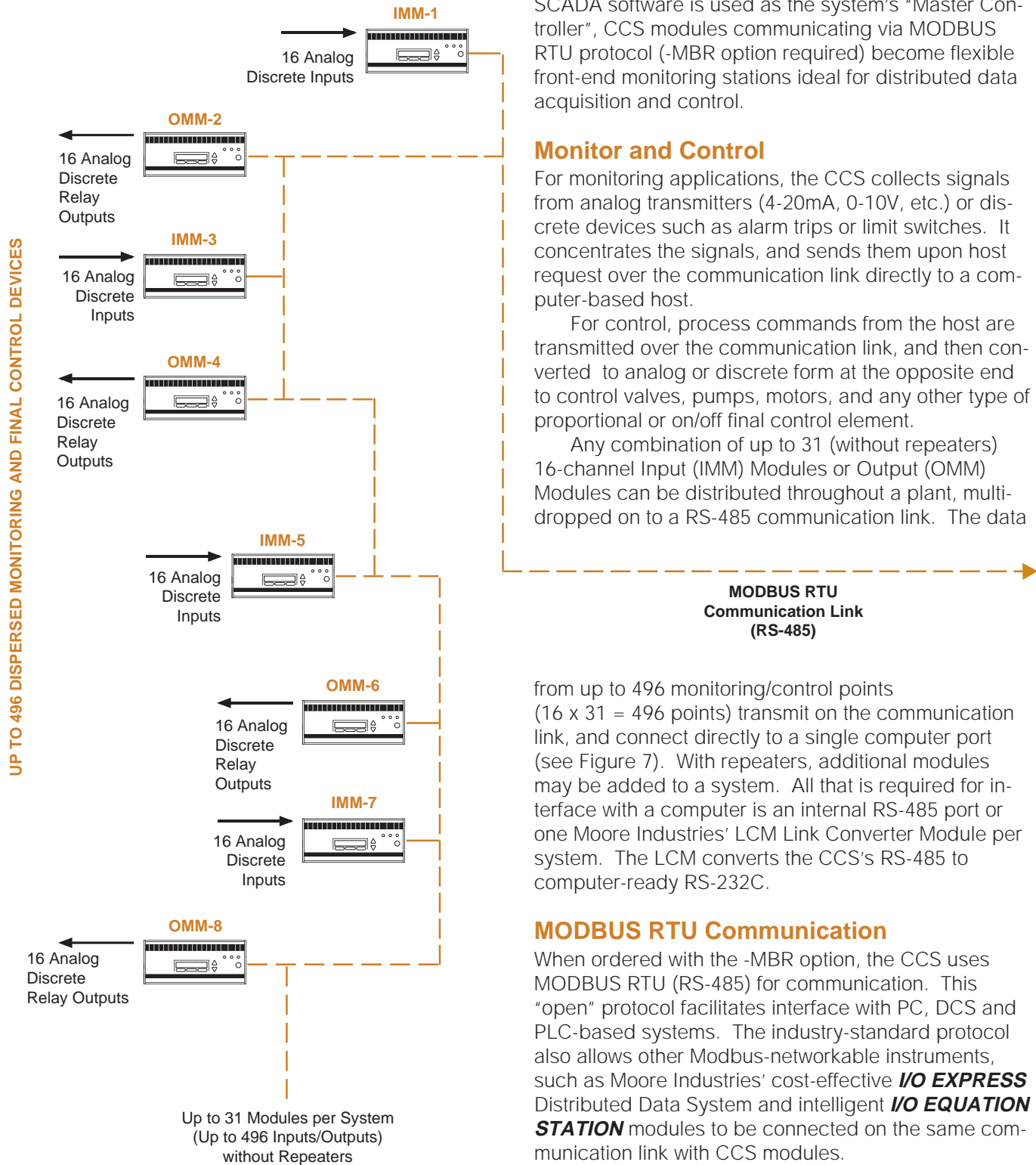

Figure 7. Using standard MODBUS RTU communication (-MBR option required), the CCS is the ideal front end for computer-based monitoring and control systems.



Peer-to-Host Systems

When a computer-based system running MMI or SCADA software is used as the system's "Master Controller", CCS modules communicating via MODBUS RTU protocol (-MBR option required) become flexible front-end monitoring stations ideal for distributed data acquisition and control.

Monitor and Control

For monitoring applications, the CCS collects signals from analog transmitters (4-20mA, 0-10V, etc.) or discrete devices such as alarm trips or limit switches. It concentrates the signals, and sends them upon host request over the communication link directly to a computer-based host.

For control, process commands from the host are transmitted over the communication link, and then converted to analog or discrete form at the opposite end to control valves, pumps, motors, and any other type of proportional or on/off final control element.

Any combination of up to 31 (without repeaters) 16-channel Input (IMM) Modules or Output (OMM) Modules can be distributed throughout a plant, multi-dropped on to a RS-485 communication link. The data

from up to 496 monitoring/control points (16 x 31 = 496 points) transmit on the communication link, and connect directly to a single computer port (see Figure 7). With repeaters, additional modules may be added to a system. All that is required for interface with a computer is an internal RS-485 port or one Moore Industries' LCM Link Converter Module per system. The LCM converts the CCS's RS-485 to computer-ready RS-232C.

MODBUS RTU Communication

When ordered with the -MBR option, the CCS uses MODBUS RTU (RS-485) for communication. This "open" protocol facilitates interface with PC, DCS and PLC-based systems. The industry-standard protocol also allows other Modbus-networkable instruments, such as Moore Industries' cost-effective **I/O EXPRESS** Distributed Data System and intelligent **I/O EQUATION STATION** modules to be connected on the same communication link with CCS modules.

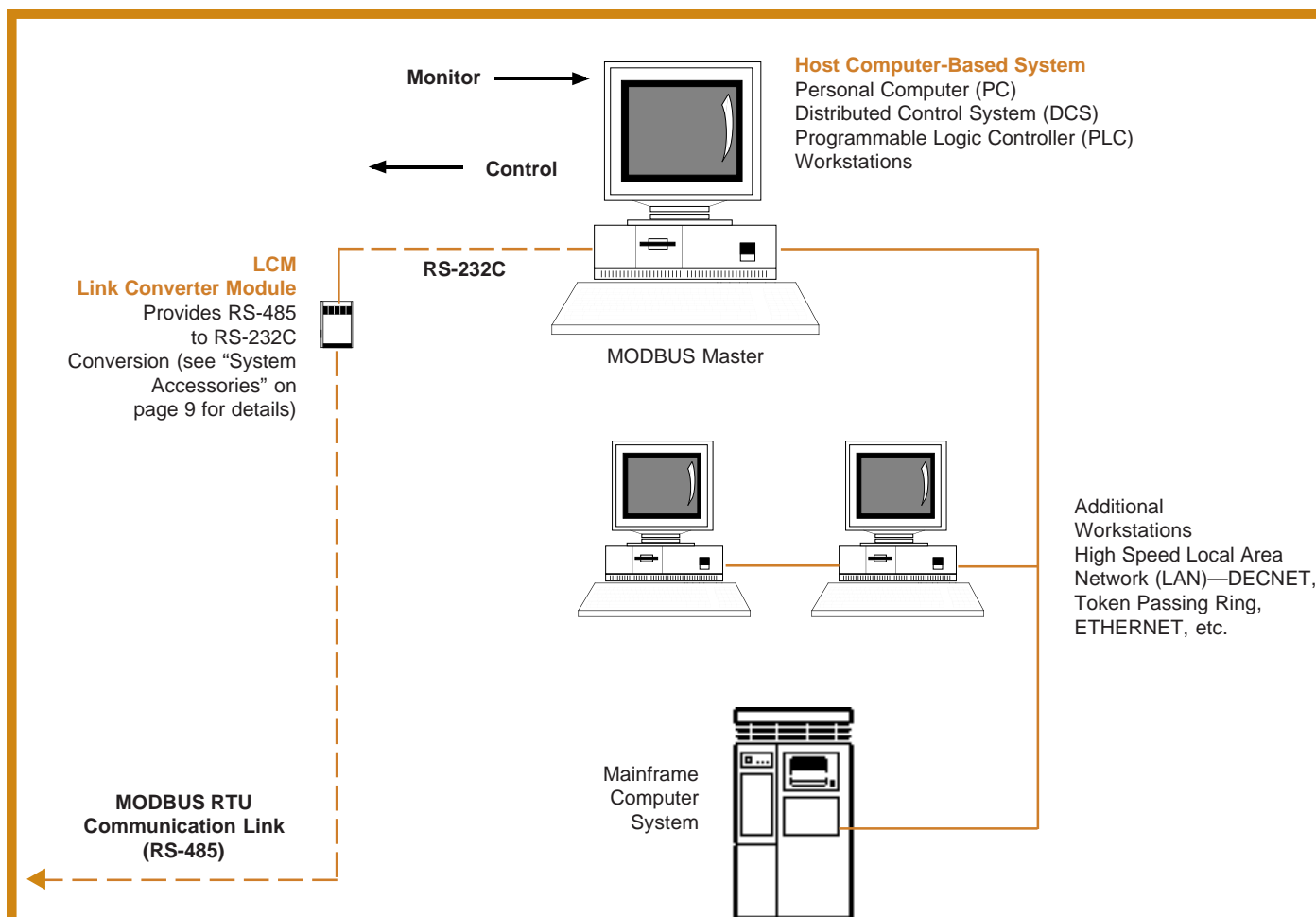

Compatible with MMI Software

Once the computer-ready data is delivered to the host computer or DCS, leading third-party MMI software packages can be used to create custom data acquisition and control strategies:

- Intellution[®] FIX DMACS[™]
- USDATA[®] FactoryLink[®]
- Wonderware[®] InTouch[™]
- INTEC Paragon
- Ci Technologies Citect for Windows[™]

These, and other, available packages allow a multitude of strategies that incorporate data acquisition, alarm summary and management, data logging and reporting, historical data collection and trending, and supervisory control functions.



Versatile COMM Link Options

Versatile communication link options overcome long-distance, normally impassable, and hazardous environments:

Twisted Wire Pair

Transmitting CCS signals at 4800 baud over a standard 24AWG shielded twisted wire pair is perfect for the majority of applications. Connected in a multidrop fashion, a twisted wire communication link delivers economical transmission of signals up to 2 miles (3.2km). Larger gauge wires, such as 12 or 18AWG, allow use of faster baud rates while increasing unassisted transmission distances. Repeaters can be used to increase transmission distances even further.

Telephone Modem

Inexpensively transmit process data unlimited distances over leased or dial-up telephone lines. We offer modems and RS-485 to RS-232C/RS-422 (for modem) converters.

Radio

Where wires can't be run, such as over water, radio (RF) communication provides accurate and reliable signal transmission.

Fiber Optic Cable

For hazardous or exceptionally noisy environments, light is an effective strategy. We offer fiber optic converters and other accessories needed for interface.

Redundant Communication Links

For CCS Peer-to-Peer System applications where you can't afford to lose data, a second, back-up communication link can be run by adding RLM Redundant Link Modules to the system.

Installed at each end of the communication link, the RLM automatically switches the signal being transmitted by the CCS to a secondary communication link should the primary link be severed or otherwise interrupted. For added safety, the links can even be run in two completely different paths without compromising system performance.

Two RLMs are required per Peer-to-Peer System, which may include up to eight pairs of IMM Modules and OMM Modules (see Figure 8).

The RLM senses a signal transmission interruption via the IMM's or OMM's fault relays. When an IMM or OMM fault relay is tripped by a communication link interruption, the RLM switches transmission from the primary link to the secondary link, restoring system communication. Transmission will continue on the secondary link until a reset button located on the RLM's front panel is pressed.

Figure 8. In Peer-to-Peer Systems, redundant communication links assure continuous data flow should the primary link be compromised.

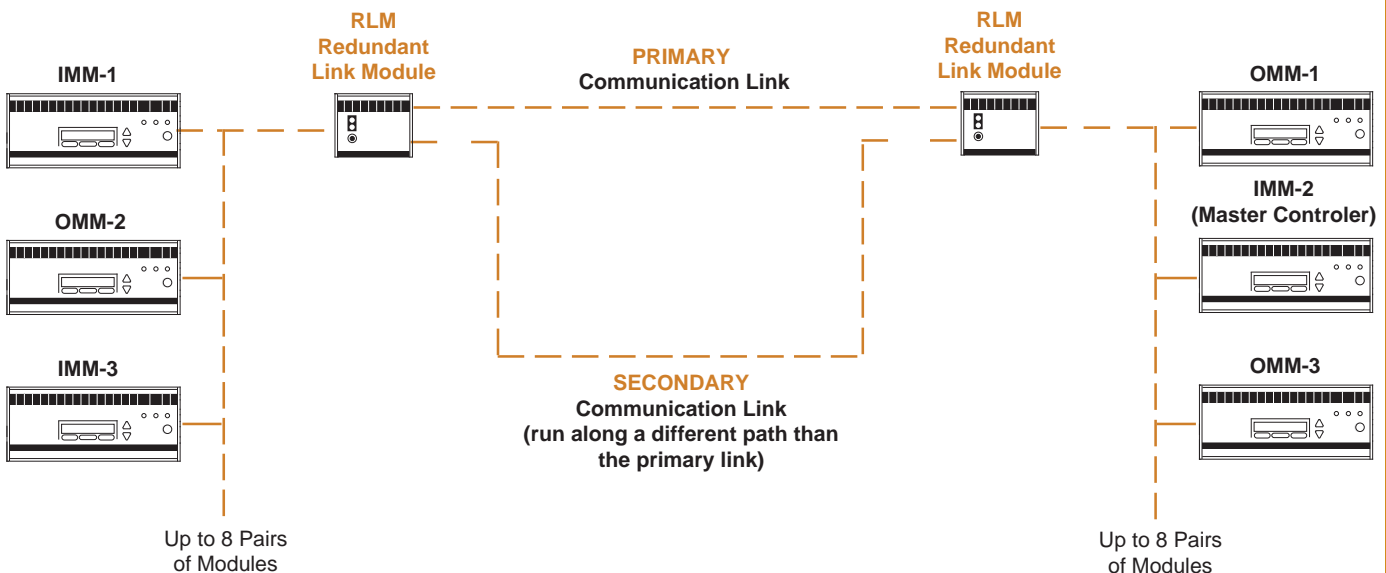

System Accessories

RS-485 to RS-232C/RS-422 Converter

Moore Industries' LCM Link Converter Module converts the CCS's RS-485 to either an RS-232C or RS-422 standard to allow direct interface with a modem or computer-based system, such as a PC. Two DIN-style LCMs are required for each 128 point Peer-to-Peer System (for modem interface). Only one is required for each 496 point Peer-to-Host System. For details, see the LCM & LFM data sheet (#14.20).

RS-485 to Fiber Optics Converter

The LFM Link-to-Fiber Optic Module converts the CCS's RS-485 signal to light for signal transmission over a fiber optic cable. Two DIN-style LFMs are required for each 128 point System. For details, see the LCM & LFM data sheet (#14.20).

Short Haul Modem

The Short Haul Modem extends the CCS's allowable transmission distance to 10 miles (16km). The LCM is used to convert the CCS's RS-485 signal to the RS-232C signal required for the Short Haul Modem. The Short Haul Modem is for use with 4-wire continuous, non-switched lines.

Accessory/Part	Ordering No.
Short Haul Modem (two required) LCM-to-Modem Cable (two required)	800-892-45 801-858-26

Dial-Up Modem

The Dial-Up or Dedicated Modem permits unlimited transmission distances over a regular switched telephone line or a leased dedicated line (leased line modems are required for Peer-to-Host Systems). The LCM is used to convert the RS-485 signal to the RS-232C signal required by the modem.

Accessory/Part	Ordering No.
Dial-Up Modem (two required) LCM-to-Modem Cable (two required)	800-899-45 801-870-26

RS-485 Repeater

This extends the CCS's transmission distance an additional 10,000 feet over its limit.

Accessory/Part	Ordering No.
RS-485 Repeater	800-897-45

Radio Transceiver and Radio Modem

This combination permits signals to be transmitted where it is physically, economically, or environmentally impossible to run hard wiring. Use the LCM to convert the CCS's RS-485 signal to the RS-232C signal required by the equipment.

Accessory/Part	Ordering No.
Radio Transceiver (two required) Radio Modem (two required) LCM-to-Modem Cable (two required)	800-895-45 800-896-45 Consult Factory

Data Line (Surge) Protector

Mounts on a G-type rail next to the CCS to protect the communication link from damaging voltage and current surges caused by lightning, welding, heavy electrical equipment, and switch gears.

Accessory/Part	Ordering No.
Data Link Protector (two required per link)	800-893-61

Redundant Power Supply

Moore Industries' SSM Supply Switching Module provides a redundant power supply to the CCS. The DIN-style, rail-mount SSM accepts two power supply inputs and provides an interrupted power source by passing on the highest voltage.

Accessory/Part	Ordering No.
SSM Supply Switching Module (Each can power up to 5 CCS modules)	SSM / 2X24DC / 24DC / SP [DIN]

Instrument Power Supplies

Moore Industries offers a complete line of instrument power supplies for mounting alongside and powering the CCS Cable Concentrator System. For details, see the DPS1200 (#11.10) and SMP (#11.30) data sheets.

Instrument Panels and Systems

Let us integrate and package your CCS into a ready-to-install instrument sub-system. CCS accessories, other instrumentation, cabinets, wiring, relays, power supplies—whatever is required—we can supply and assemble.

Our UL 508 Certified panel shop services include design-to-ship responsibility, complete documentation, expert technical assistance, and 100% component and system testing.

Specifications

<p>Performance Calibration Capability: ±0.1% of max. span for analog input and ±0.1% of max. span for analog output</p> <p>Isolation: IMM Input Module: Analog/TTL inputs isolated to 175Vdc or ac peak between channels; 500Vac between inputs, power, and data link</p> <p>OMM Output Module: Analog outputs have common negative; discrete outputs are isolated 500Vac between outputs/power/data link</p> <p>Impedance: IMM Voltage: 1MΩ IMM Current: 250Ω</p> <p>Drive Capability: OMM Analog: 0-20mA into 0-850Ω; 0-10V output limited to 20mA OMM Discrete (Open Collector): External power, 42Vdc @ 100mA</p> <p>System Fault Contact: 120Vac @ 0.5A or 24Vdc @ 1A (non-inductive)</p> <p>Discrete Output Protection: MOV protected on all contact closure and relay channels (discrete channels on Universal modules are not protected)</p>	<p>COMM Link (Twisted Wire Pair)</p> <p>Baud Rate: Any rate from 600 through 19,200 is user-selectable</p> <p>Transmission Range: Using 24AWG twisted pair wiring, max. of 2 miles (3.2km) @ 4800 baud or less; max. of 1 mile (1.6km) @ 9600 baud; max. of 0.5 miles (0.8km) @ 19200 baud (modems and repeaters are offered to increase allowable transmission distances)</p> <p>Surge Protection: Order Part Number 800-893-61 for communication link surge protector (see CCS Accessories for details)</p> <p>Power Supply</p> <p>IMM Input Module (current consumption @ 24Vdc, nominal): Analog Inputs: 175mA Discrete Inputs: 335mA Mixed Inputs (Universal Module): 335mA max.</p> <p>OMM Output Module (current consumption @ 24Vdc, nominal): Analog Outputs: 500mA Discrete Outputs: 500mA with "R" output type, 335mA with "T" output type Mixed Outputs (Universal OMM): 500mA</p>	<p>Ambient Temperature</p> <p>Operating Range: 0 to +65°C (+32 to +150°F)</p> <p>Ambient Temperature Effect: Less than ±0.01%/°C (analog inputs and outputs from 0 to +65°C)</p> <p>Adjustments</p> <p>Front Panel Pushbuttons: Configure and calibrate module channels, configure master/slave, clear alarms, and activate/de-activate modem software</p> <p>Internal Solderless Jumpers: Configure channels for analog (current or voltage) or discrete (contact closure) inputs/outputs</p> <p>Indicators</p> <p>Integral Display: 16-character LCD shows module identification number, channel number, and process value during configuration, calibration, and operation</p> <p>Front Panel LEDs: Indicate module is transmitting/receiving data properly, and when the unit is in a fault condition</p> <p>Weight 2lbs., 14 oz. (1.3Kg) per module</p>
--	---	--

Programmable Inputs/Outputs

The extensive capabilities of the CCS Cable Concentrator System provide for a wide range of input and output possibilities.

Using on-board controls, the CCS programs to accommodate a wide range of signal input/output types and ranges. Unlike most comparable systems, you are not locked in by input/output-specific "blocks" that plug into an expensive, multiposition rack or back plane.

Further adding to system flexibility, any combination of CCS modules (Universal and Discrete) may be used on the same communication link. However, in a Peer-to-Peer System Universal IMM must be paired with a Universal OMM, and a Discrete IMM must be matched with a Discrete OMM.

Use Table 1 on the next page to choose the desired input and output combinations, and match IMM Input Modules to OMM Output Modules.

Ordering Specifications

Unit	Input	Output	Power	Options	Housing
<p>IMM Input Module (16 channels per module; 8 modules per system max.)</p> <p>OMM Output Module (16 channels per module; 8 modules per system max.)</p> <p>NOTE: For Peer-to-Peer Systems, IMM and OMM modules must be ordered in pairs, with a maximum of eight pairs per system.</p>	<p>(See Table 1 for descriptions)</p> <p>IMM INPUT MODULE: U 16 input channels configure to accept any combination of analog and/or discrete signals; in Peer-to-Peer Systems, pair with OMM with "U" output type</p> <p>D 16 input channels accept discrete signals; In Peer-to-Peer Systems, pair with OMM with "R" or "T" output type</p> <p>OMM OUTPUT MODULE: RS485 communication from a matching IMM module or computer-based host</p>	<p>(See Table 1 for descriptions)</p> <p>IMM INPUT MODULE: RS485 to a matching OMM or computer-based host</p> <p>OMM OUTPUT MODULE: U 16 output channels configure to accept any combination of analog and/or discrete signals; In Peer-to-Peer Systems, pair with IMM with "U" input type</p> <p>R 16 relay output channels (-NC or -NO option required)</p> <p>T 16 discrete output channels (contact closure)</p>	<p>18-30DC 24Vdc nominal or 24Vac, ±10%, 50/60Hz</p>	<p>-MBR MODBUS RTU communication link for Peer-to-Host Systems (not available with Peer-to-Peer Systems)</p> <p>-NC Normally closed relays (R-type OMM only, see Table 1)</p> <p>-NO Normally open relays (R-type OMM only, See Table 1)</p>	<p>DIN Aluminum rail-mount housing mounts on 32mm G-type (EN50035) and 35mm Top Hat (EN50022) rails</p> <p>(single and multi-unit enclosures and cabinets available, call for details)</p>

When ordering, specify: Unit / Input / Output / Power / Options [Housing]
Model number examples: IMM / U / RS485 / 18-30DC / -MBR [DIN]
 OMM / RS485 / U / 18-30DC [DIN]

Table 1. Compatible Module Types and Input/Output Possibilities

Module Type	Signal Direction	Input/Output Signal Possibilities
UNIVERSAL—Analog and/or Discrete Inputs with Analog and/or Discrete Outputs		
IMM Universal Inputs (U)	Input	Each channel is user-configurable to accept any combination of: Analog Signals—Current (any range between 0-20mA such as 4-20mA, with 8mA span min.) or voltage (any range between 0-10V such as 1-5V, with 4V span min.) Discrete Signals—Contact closure (switch point 3.0Vdc) or TTL signals configurable to represent HIGH/LOW, OPEN/CLOSE, or any ON/OFF state.
	Output	RS-485 for transmission to a matching Universal (U) OMM, or to a computer-based host
OMM Universal Outputs (U)	Input	RS-485 transmitted from a matching Universal (U) IMM, or from a computer-based host
	Output	Each channel is user-configurable to output any combination of: Analog Signals—Current (any range between 0-20mA such as 4-20mA, with 8mA span min.) for voltage (any range between 0-10V such as 1-5V, with 4V span min.) Discrete Signals—Contact closure (42V, 100mA max. at 1.5V drop) or TTL signals configurable to represent HIGH/LOW, OPEN/CLOSE, or any ON/OFF state
DISCRETE—Discrete Inputs with Mechanical Relay or Contact Closure Outputs		
IMM Discrete (D)	Input	Each channel is user-configurable to accept any combination of: Contact Closure (switch point 1.0Vdc) or TTL signals configurable to represent HIGH/LOW, OPEN/CLOSE, or any ON/OFF state
	Output	RS-485 for transmission to a matching OMM with "R" or "T" output type, or to a computer-based host
OMM with R -Type Outputs	Input	RS-485 for transmission to a matching Discrete (D) IMM, or from a computer-based host
	Output	Mechanical Relay Outputs: Normally-closed (-NC option) or normally-open (-NO option) relay output rated 5A @ 250Vac or 5A @ 30Vdc (resistive loads)
OMM with T -Type Outputs	Input	RS-485 transmitted from matching Discrete (D) IMM, or from a computer-based host
	Output	Contact Closure (42V, 100mA max. at 1.5V drop) signals configurable to represent HIGH/LOW, OPEN/CLOSE, or any ON/OFF state

Data and System Reliability

Digital transmission on the CCS's communication link assures accurate and fast data transmission. This, combined with complete input/output/power isolation provides virtual immunity to inaccurate readings caused by ground loops, RFI/EMI, and other electrical interferences.

Hardware Integrity

The CCS's comprehensive hardware testing includes dozens of tests at the component, board, assembled module, and completed system levels. In addition, each CCS module is equipped with a fault relay contact that provides an external alarm and a built-in display for visually checking transmitted data.

Firmware Integrity

The CCS's internal firmware incorporates built-in diagnostics to detect hardware and software failures, and provide continuous data checking of communication link transmissions. In addition, the software has a watchdog timer to restart the program if power to the unit is interrupted. The CCS's alarm log stores up to 99 alarms (the first 98 in and the last one received). For added system security the CCS stores preprogrammed default values which hold outputs at a predetermined level or state should communication be interrupted.

Application Versatility

Just a few of the wide range of applications where the CCS is delivering solutions:

- **Chemical Plant** sent ninety-six 4-20mA signals from dispersed reactors 13,000 feet back to a control room on one twisted wire pair.
- **Fertilizer Production Facility** sent 24 discrete alarm status signals 1.3 miles from a water intake station to the mill control room and sixteen 4-20mA control signals back to pumps at an intake station.
- **Power Generating Station** avoided plant electrical noise by sending 46 signals over a computer cable from boilers to a flow computer.
- **Steel Mill** used the CCS, modems, and existing telephone line to transmit 14 discrete and nine 1-5V signals from a foundry 500 feet back to a mill.
- **Oil Refinery** sent 4-20mA signals representing combustible levels of gas 3,500 feet from LPG tanks through a hazardous area using safe fiber optic cable.
- **Brewery** transmitted sixteen 4-20mA pressure signals to a bottling line, and saved the cost of running 16,000 feet of pneumatic tubing.
- **Dredging Company** used the CCS and radio communication link to send signals from a dredge ship to a shore station.
- **Sewage District** transmitted CCS signals from dispersed locations over fiber optic cable to avoid the possibility of explosions in underground piping.

Figure 9. Installation Dimensions.

