

Description

The FDY PC-Programmable Frequency-to-DC Transmitter with Display monitors frequency, period, high or low pulse width, and contact closure signals. It converts the input signal to a proportional, input-to-output isolated 4-20mA output ready for direct interface with a readout instrument, recorder, PLC, DCS, SCADA system or other readout instrument.

The 2-wire (loop-powered) FDY is ideal for use in a wide range of process and factory automation monitoring applications:

- Turbine Tachometer Generators
- Turbine Flow Meters
- Magnetic Pickups • Dry Contact Closures
- Variable Frequency Drives • Rotating Equipment
- Pulse and Frequency Output Transducers
- Motor and Conveyor Speed



The FDY installs quickly and easily in harsh conditions using our protective field-mount enclosures, or on a surface, DIN-rail or relay track.

Figure 1. The FDY configures with application-specific operating parameters in just minutes using our single-window Intelligent PC Configuration Software

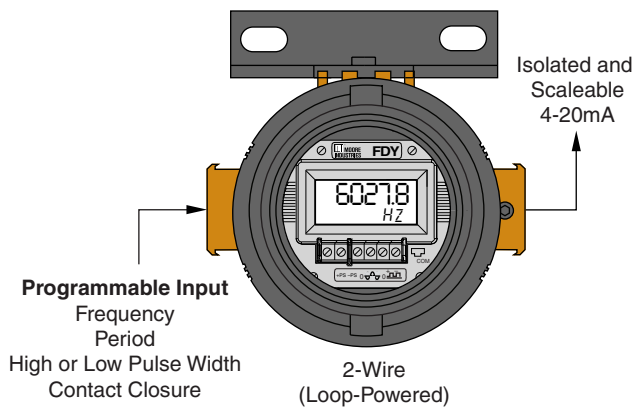

Features

- **Exceptional accuracy and long-term stability.** Typical accuracy is $\pm 0.025\%$ of span with up to 5 years between scheduled calibrations.
- **Sets up in minutes with PC software.** You can choose, and then view to confirm, all application-specific operating parameters.
- **Versatile input choices.** Measures frequency ranges between an amazingly low 0.005Hz up to 25kHz; periods from 40microseconds to 200sec; and pulse widths from 0.2msec to 200 seconds.
- **User-configurable display.** A 5-digit LCD shows the process variable in selectable engineering units.
- **Input-to-output isolated and RFI/EMI protected.** Resistant to unpredictable ground loops and the harmful effects of plant and equipment "noise".
- **Programmable moving average filter.** Minimizes measurement instability caused by the effects of bent turbine blades and other frequency variations.
- **"HelpMap Navigation System".** PC software provides quick and complete answers to setup, performance, installation and maintenance questions.

Certifications



FDY

PC-Programmable Frequency-to-DC Transmitter with Display

Accurate Frequency Monitoring

In power generating stations, stand-by power systems, and cogeneration plants, the frequency of the generated power must be tightly controlled. The FDY provides extraordinary precision for this measurement, providing a 4-20mA signal for a narrow span centered on the set point (for example, 55-65Hz for a 60Hz system).

Figure 2. Precision frequency measurement for power generators

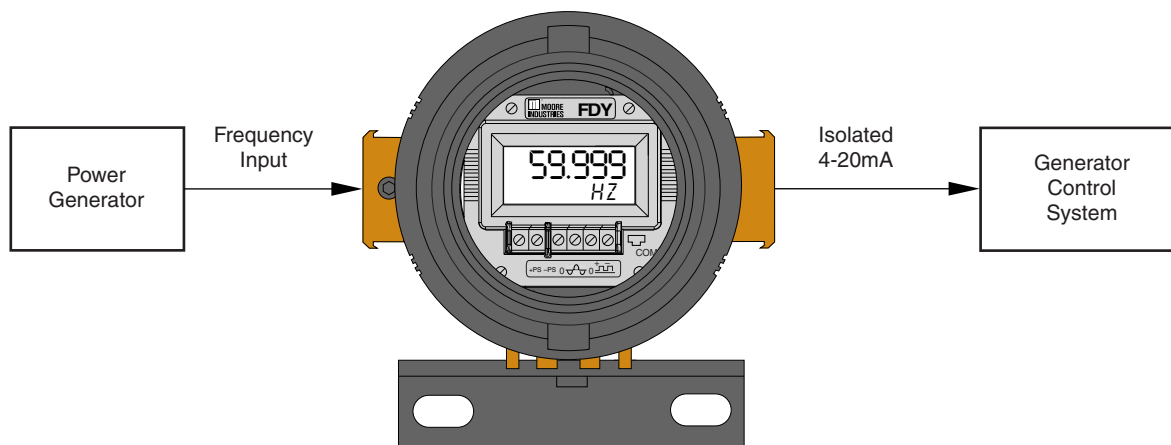

Make Consistent Flow Measurements

Flow measurements are often made with turbine flow meters. One common source of measurement inconsistencies is frequency variation due to bent blades.

Programmable Averaging Filter—To compensate for bent blades, the FDY incorporates a programmable moving average filter. The user-selectable moving average is set to match the number of turbine blades. Taking a reading from each turbine blade, the FDY averages the readings to produce a “smoothed out” 4-20mA value proportional to the continuous averaged measurement. This

advantage stretches the time between maintenance cycles needed to replace the rotor in the turbine meter by delivering accurate measurements even if the turbine blade(s) are damaged.

Custom Linearization Curves—Another potential for error is the effect of viscosity, which varies according to published curves. For liquids, the change is temperature related, while for gas, it is flow related. In some cases, the onboard linearization capability of the FDY can compensate for the viscosity effect using calibration data supplied by the meter manufacturer.

Figure 3. Programmable “filtering” features minimize the effects of bent turbine blades

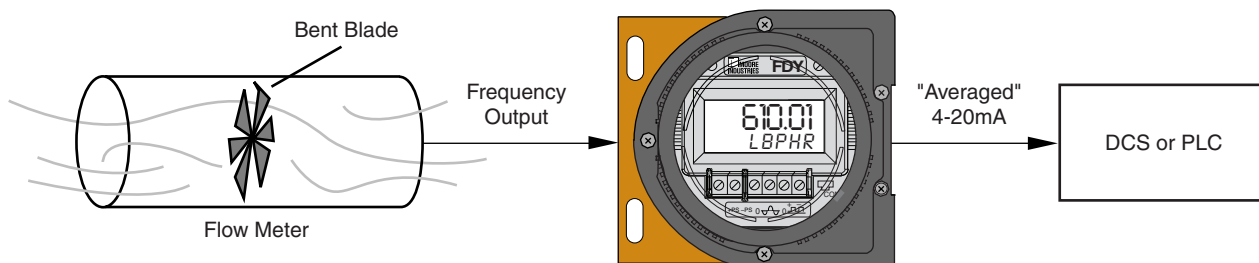

Increasing Pump Efficiency

Natural gas typically must be processed both to remove unwanted contaminants, and to separate it into different types of gas before it is usable. These gas processing plants require the raw gas to be pumped from low pressure to high pressure to produce usable products. Maintaining consistent pump speed is essential to this process to maintain efficiency and decrease wasted product.

Most pumps use jet engines to create the required pressure; however, a change in engine speed of just $\pm 0.1\%$ can vary the volume of the pump drastically. To ensure the pump is operating at the required level, it must be continuously monitored.

To accomplish this, a magnetic pickup is attached to the pump shaft (Figure 4). The pickup provides a frequency output. The FDY takes the pickup signal, converts it to a 4-20mA output proportional to the pump shaft speed, and transmits it to the DCS. Should there be an unwanted change in speed, it can be detected at the DCS.

Because of the FDY's superior accuracy, it is able to detect even slight changes in shaft speed to help ensure the pump is running at optimum efficiency.

Figure 4. Monitor pump speed to ensure optimum efficiency

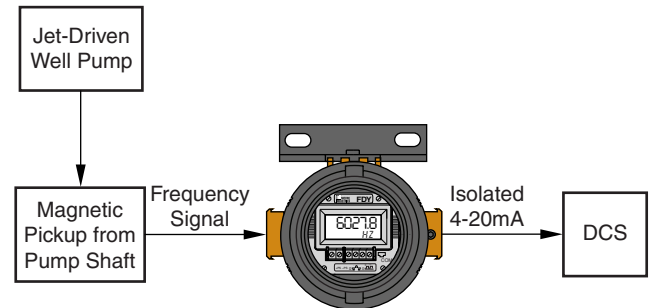

Measuring Volumetric Flow Based On Shaft Rotational Speed

Many processes require the periodic addition of precise amounts of a reagent or similar additives using a pump. Because there is a direct correlation between shaft rotation speed and the volume of product pumped, this strategy delivers a precise volume of additive for each revolution of the shaft. In this application, the FDY is used to accurately measure the RPM of the shaft, and provide a 4-20mA signal directly proportional to volumetric flow (Figure 5). The flow information is used by the control system to provide on/off pump control.

Figure 5. Precision feedback of pump shaft revolutions per minute (RPM) for monitoring additive volume

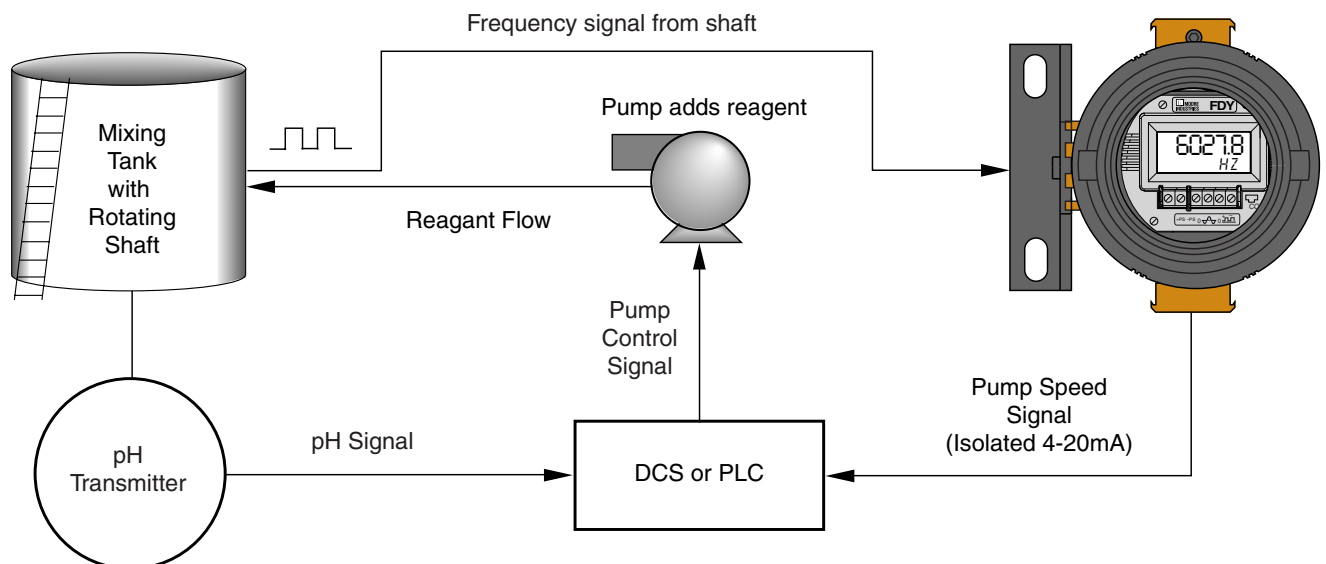

FDY

PC-Programmable Frequency-to-DC Transmitter with Display

Measuring Weight per Minute of Product Transported on Conveyor Belts

The FDY accepts the input from a magnetic pickup sensor, turbine tachometer generator, dry contact closure, or other frequency sensor. It converts the input to a user scaleable 4-20mA signal proportional to belt speed. This is useful for measuring and transmitting information from conveyer belts.

Mining and Cement Industries

The mining and cement industries often use conveyer belts to transport bulk solids. The amount of the product being moved is related to its cross sectional area, (determined by measuring the average height on the belt across a known width), the weight of the material, and the speed of the belt. (Typically, a non-contact device is used to measure the average height and provide a 4-20mA signal.)

A weighing system accepts the analog inputs for height and speed and makes the calculations for weight per minute. Moore Industries' MDS I/O Equation Station may be used to provide this calculation functionality and then report the information to a monitoring system via 4-20mA signal, discrete status and/or MODBUS RTU data.

Paper Industry

In most paper production facilities, precision control of roller speeds is critical. Use the FDY to make a speed measurement using a frequency pickup on the roller shaft. Installed in Moore Industries' NEMA 4X (IP66) D-BOX enclosure or an explosion-proof BH enclosure, the FDY can be field-mounted in rugged and hazardous field environments.

Figure 6. Used in conjunction with a weighing system, the FDY can be used for conveyer belt weight calculations

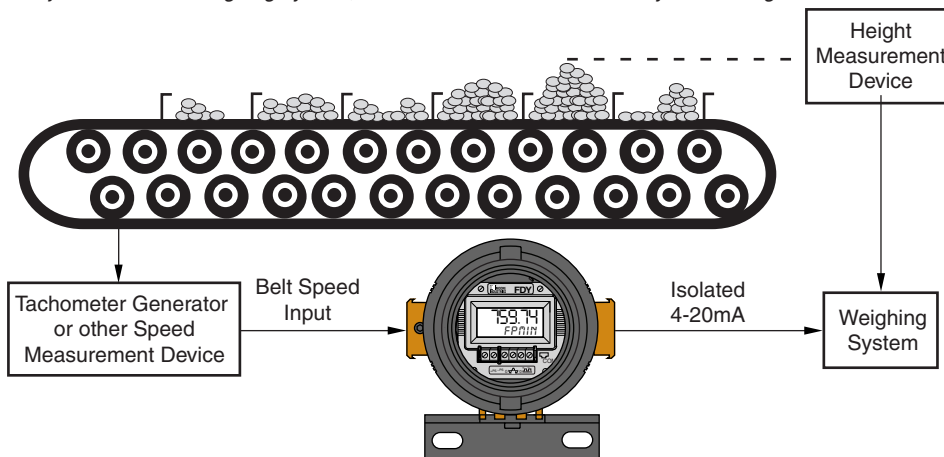

Certifications



Factory Mutual Approvals - FM Global
Explosion-Proof[†] – [HP in BH and SB Housings]
 Class I, Division 1, Groups A[†], B, C & D
Dust Ignition-Proof
 Class II & III, Division 1, Groups E, F & G
Environmental Protection: NEMA 4X; IP66.
Intrinsically Safe
 Class I, II & III, Division 1,
 Groups A, B, C, D, E, F & G.
Non-Incendive
 Class I, Division 2, Groups A, B, C, D.
 Class II & III, Division 2, Groups F & G.
Temperature Code
 T4@60°C Max. Op. Amb.



Canadian Standards Association (CSA)
Intrinsically Safe & Non-Incendive
 Class I, Divisions 1 & 2, Groups A, B, C, D.
Temperature Code
 T4@60°C Max. Op. Amb.

SAA

TestSafe (Australian) Approvals:
 Flame-Proof [HP in BH Housing]
 Ex d IIC T6@60°C



European/ATEX Directive 94/9/EC Approvals:
ISseP Flame-Proof Apparatus - [HP in BH]
 Ⓢ II 2GD EEx d IIC T6@60°C, IP66

LCIE Intrinsically Safe
 Ⓢ II 2G EEx ia IIC T4
Temperature Code
 T4@60°C Max. Op. Amb.

Type N Inherent [BH/D-Box] - Ⓢ II 3G EEx nA II T6



CE Conformant – EMC Directive 89/336/EEC
 EN 61326

[†] BH Housing—Group A only: Seal all conduits within 18".

Specifications

Performance

Input Accuracy: See Tables 2-7

Output Accuracy: ±0.015% of span

Overall Accuracy: The overall accuracy of the unit is the combined input and output accuracies. It includes the combined effects of linearity, hysteresis, repeatability, and adjustment resolution. Does not include ambient temperature effect.

Input Hysteresis: See Tables 5-7

Input Threshold: See Tables 5-7

Stability: See Table 1

Minimum Frequency: Twice the lower range

Digital Input Filter: 3dB point is at 10kHz

Step Response Time: 300msec maximum, 200msec typical from the time an input is applied to the output reaching 90% of its final value + actual input

Rise Time: 100msec maximum for the output to change from 10% to 90% of its scale of an input step change of 0% to 100% + actual input

Isolation: 500Vrms between input, output, and case continuous, and will withstand a 500Vac dielectric strength test for one minute with no breakdown

Ripple: 10mV p-p measured across a 250 ohm resistor

Overcurrent Limiting: 25mA maximum

Maximum Voltages: 48Vdc output, maximum;

Performance (Continued)

DC input, 48Vdc, maximum; AC input, 30Vac maximum for 0.02-30AC model, 250Vac maximum for 10-250AC model

Input Impedance: >30kohms for DC and contact closure inputs; 2kohms for input >6V, 4kohms typical@50Hz and 56kohms typical@1kHz for input <6V for 0.02-30AC model; >125kohms for 10-250AC model

Load Capability: 508 ohms@24V

$\text{Supply Voltage} - 12V \div 0.0236A = \text{Ohms}$

Output Current Limiting: 3.8mA and 21.4mA for input under range and over range; 3.6mA and 23.6mA for input failure

Load Effect (current outputs): Negligible within specified power limits

Power Supply Effect: ±0.002% of span per 1V change

Startup Time: Performance within specification less than 1sec after power is applied for frequency higher than 100Hz and average of 8 samples

Damping: Adjustable from 0 to 30 seconds with PC software

Linearization: Configurable up to 128 points with PC software

Moving Average: Configurable up to 16 segments with PC software

Low Pass Filter: On/Off is software configurable

Display Type: LCD; Top Row, 10.16mm (0.4 in) high black

Display (Continued)

digits on a reflective background; Bottom Row, 5.72mm (0.225 in) high black digits on a reflective background

Display Update Rate: 100msec

Format: Top row is five alphanumeric characters, plus sign and decimal point; bottom is five alphanumeric characters

Range: -99999 to 99999

Minimum Display Span: 1.00

Ambient Operating & Storage Conditions Range: -40°C to +85°C (-40°F to +185°F)

I.S. Operating Range: -40°C to +65°C (-40°F to +149°F)

Relative Humidity: 0-95%, non-condensing

Ambient Temperature Effect: Input to output, ±0.007% of span/°C maximum; Digital Accuracy, ±0.003% of span/°C maximum

RFI/EMI Immunity: 30V/m when tested according to SAMA 33.1 abc with 0.5% of span or less error; 20V/m@ 80-1000MHz, 1kHz AM, when tested according to IEC1000-4-3-1995

Noise Rejection: Common mode, 120dB typical@100mVp-p input

Weight

FDY HP: 227 grams (5.3 ounces)

FDY in BH housing with glass cover: 1451 grams (3 pounds, 12.4 ounces)

FDY in D-BOX housing: 811 grams (1 pound, 6.3 ounces)

Everything You Need is Included...

Each FDY order comes with one copy of our Intelligent PC Configuration Software (Windows® compatible) on CD and one non-isolated configuration cable.

To order additional software or cables:

Part Number	Part
750-75E05-01	Intelligent PC Configuration Software
803-039-26	Isolated Configuration Cable
803-040-26	Non-Isolated Configuration Cable

FDY

PC-Programmable Frequency-to-DC Transmitter with Display

Table 1. Stability for All Models*

	Input-to-Display (% of Reading)			Display-to-Output (% of Output Span**)		
	1 year	3 years	5 years	1 year	3 years	5 years
Frequency/Period	0.001	0.0017	0.0022	0.08	0.139	0.179
Pulse Width	1 Sec	0.001	0.0017			
	0.1 Sec	0.0015	0.0026			

*Combine Input-to-Display and Display-to-Output values to determine overall stability.
**Consult factory for improved long-term drift specifications.

Table 2. DC Input Range and Accuracy for All FDY Models

Input Type	Input Range		Accuracy (% of reading)	Min. Span
	Frequency	Amplitude		
Frequency	0.02Hz to 5kHz	100mV-30V	0.01±1LSD	See Table 8
	0.02Hz to 25kHz	200mV-30V	0.05±1LSD	
Period	200µsec to 50sec	100mV-30V	0.01±1LSD	500µsec
	40µsec to 50sec	200mV-30V	0.05±1LSD	
Pulse Width	0.5msec to 50sec	1-30V	0.05±1LSD ±2µsec	500µsec
Contact Closure	<20Hz		0.01±1LSD	0.1Hz

NOTE:
AC indicates zero-crossing signal.
DC indicates non-zero crossing signal.

Table 3. AC Input Range and Accuracy for PRG Input Type

Input Type	Input Range		Accuracy (% of Reading)	Min. Span
	Frequency	Amplitude		
Frequency	0.5Hz to 25kHz	1-30V	0.05±1LSD	See Table 8
	1Hz to 5kHz	200mV-30V	0.01±1LSD	
	1Hz to 25kHz	200mV-30V	0.05±1LSD	
	10Hz to 5kHz	20mV-30V	0.01±1LSD	
Period	40µsec to 2sec	1-30V	0.05±1LSD	500µsec
	200µsec to 1sec	200mV-30V	0.01±1LSD	
	40µsec to 50sec	200mV-30V	0.05±1LSD	
	200µsec to 100msec	20mV-30V	0.01±1LSD	

Table 4. AC Input Range and Accuracy for 10-250V Input Type

Input Type	Input Range		Accuracy (% of reading)	Min. Span
	Frequency	Amplitude		
Frequency	1Hz to 5kHz	10-250V	0.01±1LSD	See Table 8
	1Hz to 25kHz	10-250V	0.05±1LSD	
Period	200µsec to 1sec	10-250V	0.01±1LSD	500µsec
	40µsec to 50sec	10-250V	0.05±1LSD	

Table 5. Frequency Input Parameters

Input Range	Threshold		Hysteresis		Filter (3db Point)	Measured Frequency
	Resolution	Range	Resolution	Range		
100mV-30V (DC)	1mV	0.01-2.5V	1mV	0.01-1.5V	10kHz	0.02Hz to 25kHz
20mV-30V (AC)			1mV	0.002-0.15V	10kHz	0.5Hz to 25kHz
10V-250V(AC)			1mV	0.002-0.15V	10kHz	0.5Hz to 25kHz

Table 6. Period Input Parameters

Input Range	Threshold		Hysteresis		Filter (3db Point)	Measured Period
	Resolution	Range	Resolution	Range		
100mV-30V (DC)	1mV	0.01-2.5V	1mV	0.01-1.5V	10kHz	40µsec to 50sec
20mV-30V (AC)			1mV	0.002-0.15V	10kHz	40µsec to 2sec
10V-250V (AC)			1mV	0.002-0.15V	10kHz	40µsec to 2sec

Table 7. Pulse Width Input Parameters

Input Range	Threshold		Hysteresis		Filter (3db Point)	Measured Pulse Width
	Resolution	Range	Resolution	Range		
100mV-30V (DC)	1mV	0.01-2.5V	1mV	0.01-1.5V	10kHz	0.2msec to 50sec

Table 8. Frequency Range Minimum Span

Maximum Frequency Range	Minimum Span
10Hz	0.1Hz
5kHz	1Hz
25kHz	25Hz

Ordering Information

Unit	Input	Output	Power	Options	Housings
FDY PC-Programmable Frequency-to-DC Transmitter with Display	PRG Input Amplitudes Supported: 0.02-30Vac* 0.1-30Vdc* (Programmable with supplied configuration software, see Tables on Page 6 for details)	4-20MA User scalable with supplied software	12-42DC Loop-Powered 12-30DC for -ISC , -ISF , -ISE , and -NE options	-ISC CSA approved IS -ISF FM approved IS -ISE ATEX IS approved -NE ATEX Type N in BH, D-Box, or SB	BH2NG Explosion-proof enclosure with two, ½-inch NPT entry ports and a glass cover BH2TG Explosion-proof enclosure with two, ¾-inch NPT entry ports and a glass cover BH2MG Explosion-proof enclosure with two, M20 x 1.5 entry ports and a glass cover BH3NG Explosion-proof enclosure with three, ½-inch NPT entry ports and a glass cover BH3TG Explosion-proof enclosure with two, ¾-inch NPT side-entry ports, one ½-inch NPT bottom-entry port, and a glass cover BH3MG Explosion-proof enclosure with two, M20 x 1.5 side-entry ports, one ½-inch NPT bottom-entry port, and a glass cover D1LC 1-Hub, D-BOX housing with low base, clear cover, NEMA 4X (IP66) enclosure D2LC 2-Hub, D-BOX housing with low base, clear cover, NEMA 4X (IP66) enclosure HP Hockey-puck housing with spring clips for mounting in standard field enclosures DN Snap-in mounting for HP case on TS-32 DIN-rail FL Mounting flanges on HP suitable for relay track or surface-mounting FLD Mounting flanges on HP suitable for 3½" relay track mounting
	10-250V Input Amplitudes Supported: 10-250Vac* 0.1-30Vdc* (Programmable with supplied configuration software, see Tables on Page 6 for details)				
*AC indicates zero-crossing signal; DC indicates non-zero crossing signal		A suffix indicates SAA/TestSafe (Ex d) Flame-Proof approvals (i.e. BH2NGA) E suffix indicates ATEX (EEx d) Flame-Proof approvals (i.e. BH2NGE) P suffix indicates enclosure comes equipped with base plate and U-bolts for mounting on a 2-inch pipe (i.e. BH2NGP)			

When ordering, specify: Unit / Input / Output / Power / Options [Housing]
Model number example: FDY / PRG / 4-20MA / 12-42DC [BH2NGP]

Figure 7. FDY Dimensions (Unit with FL Mounting Flanges Shown)

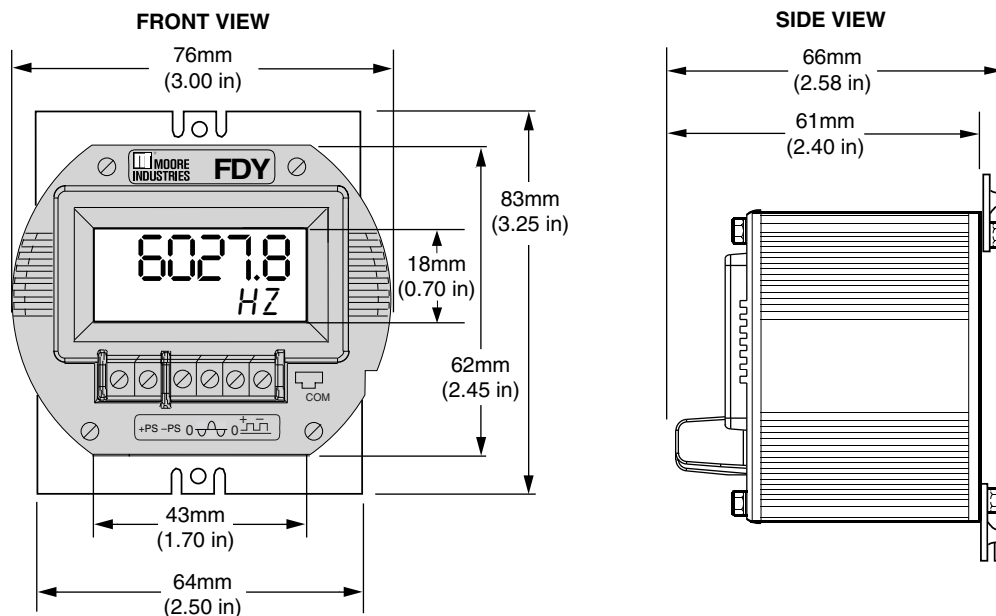

FDY

PC-Programmable Frequency-to-DC Transmitter with Display

Figure 8. BH Enclosure Dimensions

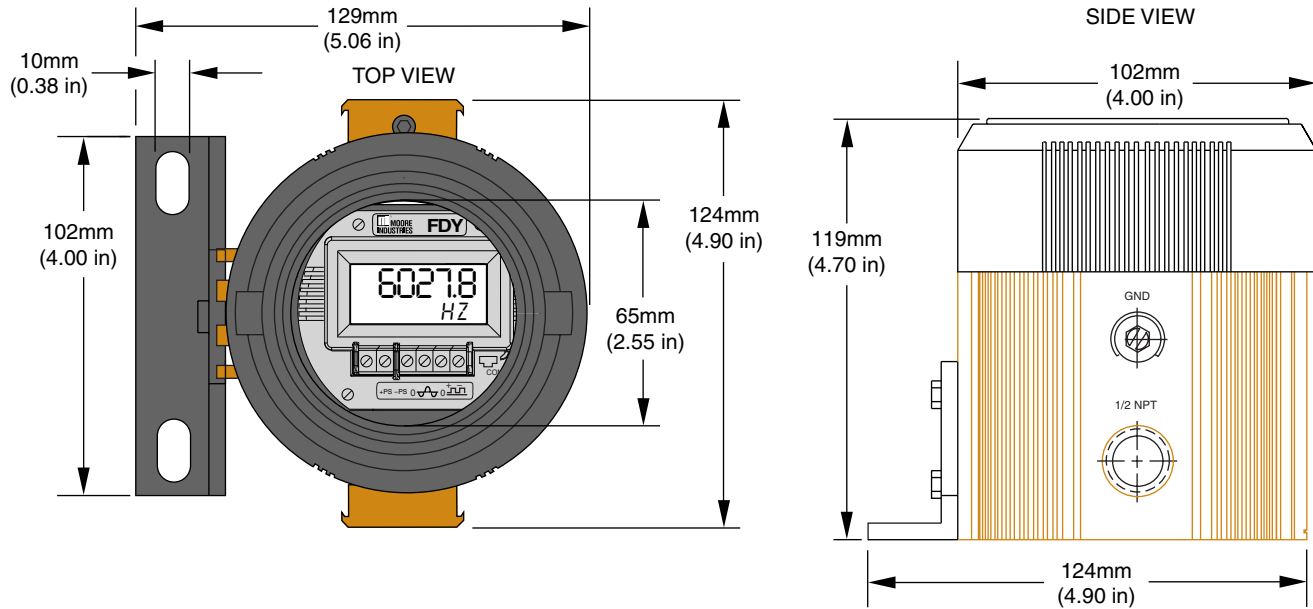
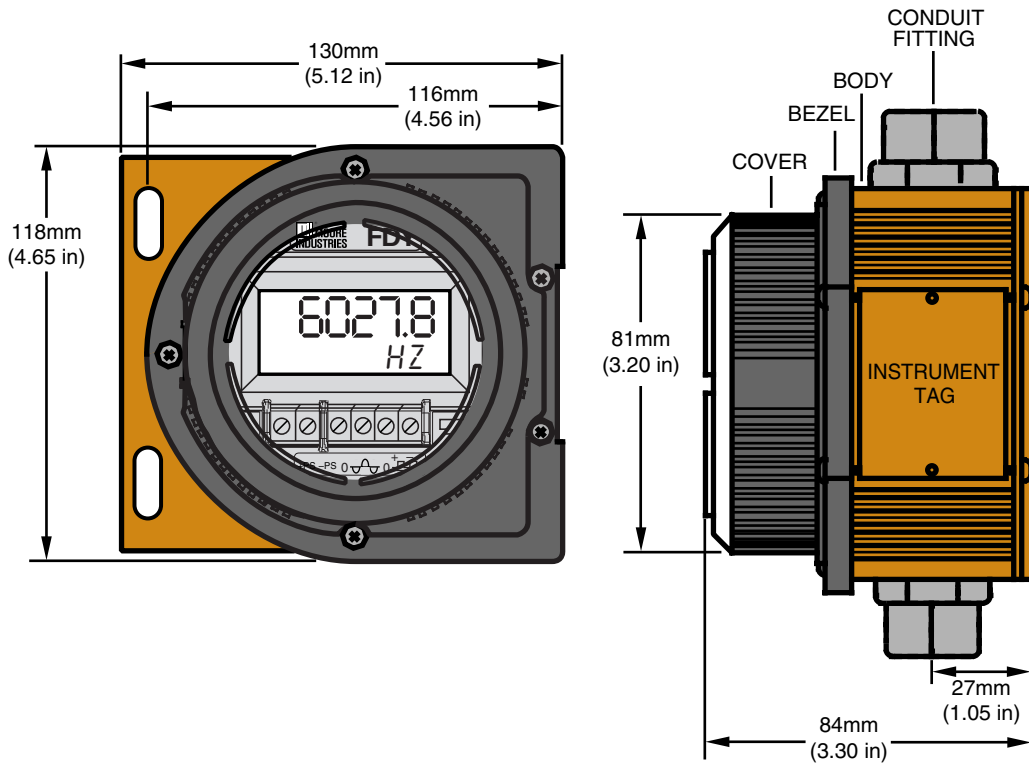

Figure 9. D-BOX Enclosure Dimensions



United States • info@miinet.com
 Tel: (818) 894-7111 • FAX: (818) 891-2816
 Australia • sales@mooreind.com.au
 Tel: (02) 8536-7200 • FAX: (02) 9525-7296

Belgium • info@mooreind.be
 Tel: 03/448.10.18 • FAX: 03/440.17.97
 The Netherlands • sales@mooreind.nl
 Tel: (0)344-617971 • FAX: (0)344-615920

China • sales@mooreind.sh.cn
 Tel: 86-21-62491499 • FAX: 86-21-62490635
 United Kingdom • sales@mooreind.com
 Tel: 01293 514488 • FAX: 01293 536852

The Interface Solution Experts • www.miinet.com