

Description

Moore Industries' rugged and compact IPH Field-Mount Current-to-Pressure (I/P) Transmitter is designed specifically for extended duty in harsh field environments.

The 2-wire (loop-powered) IPH accepts a 4-20mA input from a DCS, PLC or PC-based control system. It converts the current signal to a pneumatic signal (3-15psig, 0.2-1 Bar, 20-100 kPa, etc.) to provide precise proportional control of valves, actuators, and other pneumatically-controlled devices. Reverse pneumatic outputs (15-3psig, 1-0.2 Bar, 100-20 kPa, etc.) are also available.

The IPH is available with an optional coalescing filter/regulator that combines an air filter and miniature supply line regulator with a pressure gauge that reads in both psi (0-60) and Bars (0-4).



Exceptionally compact, the IPH's versatile mounting bracket provides quick installation, in any position (vertical or horizontal), on a surface or a 2-inch pipe.

Figure 1. The IPH converts a current signal to a pneumatic signal so that a DCS, PLC, or PC-based control system can precisely control a pneumatic valve or actuator.

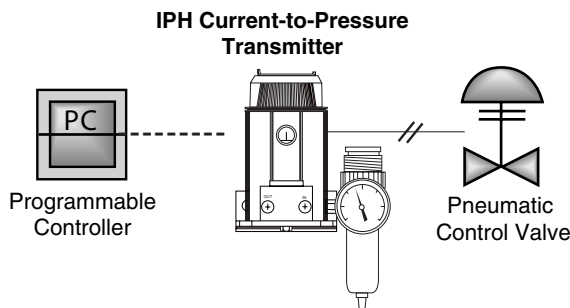

Features

- Perfect for harsh field environments.** Meeting NEMA 4X and IP65 requirements, the IPH is watertight, dust-tight, and resistant to corrosion and chemicals.
- Saves installation costs.** Use the IPH to reduce costs by running electrical wiring instead of fragile and expensive pneumatic tubing to remote pneumatic devices.
- Mounts in any position.** The IPH's superior electromechanical design allows it to be mounted in any position without affecting performance.*
- Vibration resistant.** Featuring an advanced high-technology sensor, the IPH operates flawlessly even when mounted next to a valve or similar high-vibration equipment.
- RFI/EMI protection.** Special circuit and housing designs protect against the harmful and unpredictable effects of radio frequency and electromagnetic interference.

*For NEMA4X and IP65 Installations, the unit must be mounted vertically or within 45 degrees of vertical.

IPH

Field-Mount

Current-to-Pressure Transmitter

Specifications

<p>Performance Accuracy: Less than 0.5% of span including the combined effects of linearity, hysteresis, and repeatability-defined as independent linearity per SAMA standard PMC 20.1-1973. (For 3-27psig, error will not exceed 1% of span)</p> <p>Step Response: 0.3 seconds into 100ml (6 cu. in.) at 90% of output span</p> <p>Supply Pressure Effect: Maximum 0.3%/1.4psig (0.3%/0.1BAR)</p> <p>Air Consumption: 0.1 SCFM (dead-ended)</p> <p>Air Capacity: 1.4 SCFM maximum</p>	<p>Performance (continued) Maximum Input: 150% of input span without damage</p> <p>RFI/EMI Effect: With field strengths of 10 volts per meter, at frequencies of 20-1000MHz, less than $\pm 0.1\%$ of span change (standard)</p> <p>Mounting Position Effect: Negligible, unit mounts in any position, but should be calibrated in final orientation</p> <p>Ambient Temperature Range: -40 to $+60^{\circ}\text{C}$ (-40 to $+140^{\circ}\text{F}$)</p> <p>Effect: Less than $\pm 0.1\%$ of input span per $^{\circ}\text{C}$ over range ($0.005\%/^{\circ}\text{F}$)</p>	<p>Adjustments Zero: Multiturn screw adjusts zero to $\pm 3\%$ of span</p> <p>Span: Multiturn potentiometer fully adjustable to 100% of output span</p> <p>Connections Pneumatic: 1/4-inch NPT female for both supply air and output air. Air supply also has an additional (normally plugged) port for optional filter/regulator (-FR1 option)</p> <p>Electrical: WDNS and WDNA, 1/2-inch NPT female; WDMS and WDMA, M20 x 1.5 female</p> <p>Weight 2 lbs., 3 oz. (993 grams)</p>
---	--	--

Ordering Information

Unit	Input	Output*	Supply Pressure	Options	Housing
IPH Current-to-Pressure Transmitter	4-20MA into 260 ohms, nominal input impedance	3-15PSIG	20PSI	-FR1 Coalescing filter, miniature supply line regulator and pressure gauge that reads psi (0-60) and Bars (0-4) -ISC CSA certified -ISE PTB certified -NE BASEEFA certified -ISCN NEPSI certified	WDNS Aluminum body with PBT polyester cover; NPT pneumatic and NPT electrical entry ports WDNA Aluminum body with aluminum cover; NPT pneumatic and NPT electrical entry ports WDMS Aluminum body with PBT polyester cover; NPT pneumatic and metric electrical entry port WDMA Aluminum body with aluminum cover; NPT pneumatic and metric electrical entry ports NOTE: Add "P" suffix to the model housing designator for 2-inch pipe mounting hardware (e.g., WDNSP, WDMSP)
		3-27PSIG	35PSI		
		15-3PSIG	20PSI		
		20-100KPA	140KPA		
		.2-1BAR	1.4BAR		
		.2-1KGC2	1.4KGC2		

*The unit's output must match the supply pressure to its right.

When ordering, specify: Unit / Input / Output / Supply Pressure / Option [Housing]

Model number example: IPH / 4-20MA / 3-15PSIG / 20PSI / -FR1 [WDNS]

Certifications



Factory Mutual Research (FMR) - FM Global

Non-Incendive –

Class I, Division 2, Groups A, B, C, D.

Suitable For Use In:

Class II, Division 2, Groups F & G;

Class III, Division 2.

T6@60°C Max. Operating Amb. Temp.

Enclosure Protection: **NEMA 4X, IP65.**



NEPSI-China

Intrinsically Safe – Ex ia IIC.



European CENELEC Approvals:

HSE-EECS/BASEEFA:

Type N/CENELEC – Ex N IIC; T6@60°C

PTB – Transducer is Intrinsically Safe:

EEx ia IIC; T6@60°C Max. Operating Amb. Temp.



Canadian Standards Association (CSA-Int'l)

Intrinsically Safe –

Class I, Division 1 & 2, Groups A, B, C, D;

Class II, Division 1, Groups E, F, G;

Class II, Division 2, Groups F & G; Class III.

T6@60°C Max. Operating Amb. Temp.

Enclosure Protection: **Type 4X, IP65.**



CE Conformant –

EMC Directive 89/336/EEC

EN 50081-2, 1993 and EN 50082-2, 1995

Figure 2. IPH Current-to-Pressure Transmitter Housing Dimensions

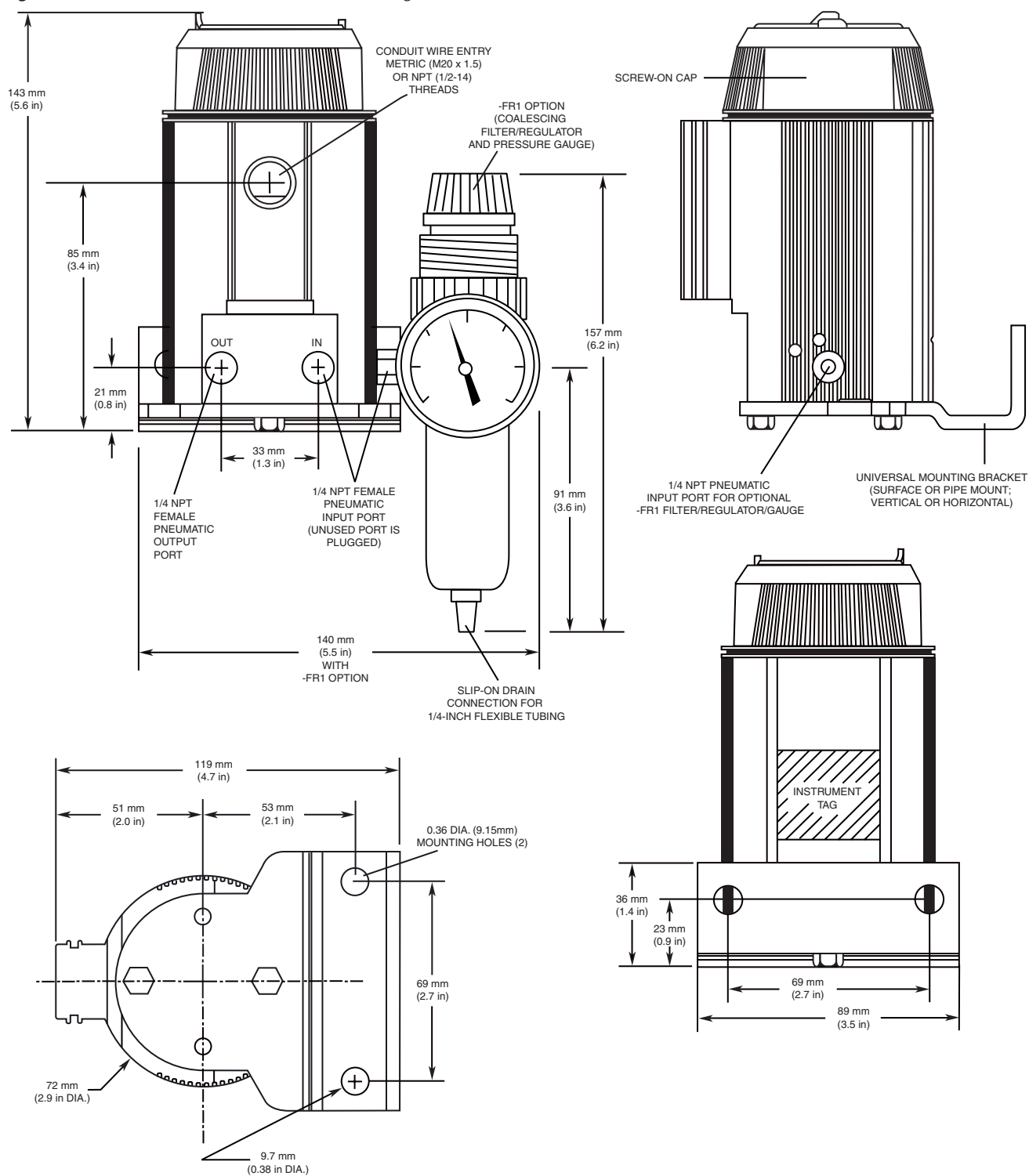

IPH

Field-Mount

Current-to-Pressure Transmitter



WORLDWIDE • www.miinet.com

United States • info@miinet.com
Tel: (818) 894-7111 • FAX: (818) 891-2816
Australia • sales@mooreind.com.au
Tel: (02) 8536-7200 • FAX: (02) 9525-7296

Belgium • info@mooreind.be
Tel: 03/448.10.18 • FAX: 03/440.17.97
The Netherlands • sales@mooreind.nl
Tel: (0)344-617971 • FAX: (0)344-615920

China • sales@mooreind.sh.cn
Tel: 86-21-62491499 • FAX: 86-21-62490635
United Kingdom • sales@mooreind.com
Tel: 01293 514488 • FAX: 01293 536852