

Description

Moore Industries' PAC and PAV Ac Current and Voltage Transducers accept an ac current (PAC) or ac voltage (PAV) input. They provide a highly accurate ($\pm 0.25\%$ of rated output) dc current output.

The PAC and PAV respond to the average value of the input signal and are calibrated to indicate the RMS value.

Monitor or Measure Power—The PAC and PAV are ideal for both monitoring and measurement applications. They monitor the electrical consumption of "load" devices such as motors and heaters or measure the amount of electricity created by "source" devices like transformers and generators. The PAC and PAV can also be used to activate an alarm should the current or voltage input value fall outside of a safety range.

Single and Triple Configurations—The PAC and PAV are offered in single and triple configurations. The compact single configuration models are ideal for single-point monitoring. The triple configuration models combine three separate input/output channels in a single housing to reduce instrument and installation costs.

Both single and triple configuration models are available in self-powered versions. These versions derive their power from the device being monitored, eliminating the need to install an additional power supply. Single configuration models are also available in auxiliary power models. These units derive their power from an external source.

Easy Installation and Maintenance—The PAC and PAV are enclosed in rugged, rustproof, extruded aluminum housings that provide superior heat dissipation. Keyhole cutout screw holes allow installation and removal simply by loosening the mounting screws.

All circuitry is attached to the unit's front panel to allow quick access to the circuitry without removing the entire housing. The circuit board slides smoothly out of the housing on PC board guides that run the entire length of the unit's housing.

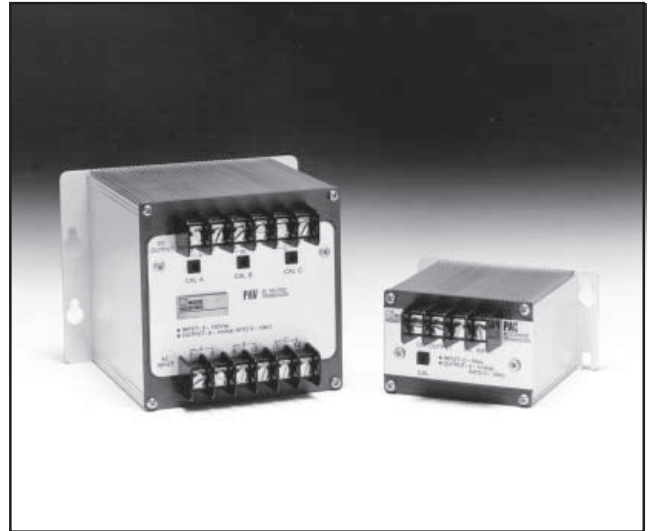

Keyhole cutout screw holes make installation and maintenance quick and simple.

Features

- **High accuracy.** $\pm 0.25\%$ of rated output accuracy makes the PAC and PAV ideal for applications where precision is demanded.
- **Transient protected.** Surge limiters provide both input and output surge protection.
- **Keyhole mounting holes.** Allows housing removal simply by loosening the mounting screws which saves time during annual calibration checks.
- **Rustproof aluminum housing.** A rugged and rustproof aluminum housing better protects circuitry to prolong service life.

Certifications



Underwriter's Laboratories: General Location

PAC & PAV

Ac Current & Voltage Transducers

Specifications

<p>Performance</p> <p>Accuracy: $\pm 0.25\%$ of rated output (from 10% to 110% of span on self-powered units) @ 25°C, $\pm 2^\circ\text{C}$</p> <p>Operating Frequency: 60Hz</p> <p>Output Ripple (peak): <0.5% of rated output (for 0-1mA PAC, ripple measured across 10K load)</p> <p>Burden: PAC self-powered, 0.5VA; PAC auxiliary-powered, 0.1VA (input terminals); PAC auxiliary-powered, 1.0VA (power terminals); PAV self-powered, 0.5VA; PAV expanded scale, 1VA; PAV auxiliary-powered, 0.02VA (input terminals); PAV auxiliary-powered, 1VA (power terminals)</p>	<p>Performance (continued)</p> <p>Dielectric Test: 2000 Vrms for one minute; 0.6KV B.I.L. (Basic Insulation Level)</p> <p>Response Time: To 90%, <200 ms; to 99%, <400 ms</p> <p>Overload: PAC with 1A, 2A, 5A, and 10A input: 3x full scale, continuous, 250A for one sec./hr.; PAC with 25A input: 35A continuous, 75A for 10 sec./hr., 250A for one sec./hr., PAV: 1.2x full scale, continuous</p> <p>Surge Withstand Capability: ANSI-C37. 90a-1974 (IEEE 472) BEAMA 219 Special 5KV</p>	<p>Ambient Temperature</p> <p>Range: -20°C to +70°C (-4°F to +158°F)</p> <p>Effect: PAC, $\pm 0.01\%/^\circ\text{C}$ ($\pm 0.018\%/^\circ\text{F}$); PAV, $\pm 0.025\%/^\circ\text{C}$ ($\pm 0.045\%/^\circ\text{F}$)</p> <p>Adjustments</p> <p>Type: Multiturn potentiometers</p> <p>Span: $\pm 10\%$ of rated output</p> <p>Zero: $\pm 2\%$ (4-20mA output); +2%, 0% of rated output span with 1mA output</p> <p>Weight</p> <p>Single Configuration: 295 grams (0.65 lbs.); with auxiliary power, 659 grams (1.45 lbs.)</p> <p>Triple Configuration: 659 grams (1.45 lbs.)</p>
------------------------------------------------------------------------------------------------------------------------------------------------------------------------------------------------------------------------------------------------------------------------------------------------------------------------------------------------------------------------------------------------------------------------------------------------------------------------------------------------------------------------------------------------------------------------------------------------------------------------------------------	---------------------------------------------------------------------------------------------------------------------------------------------------------------------------------------------------------------------------------------------------------------------------------------------------------------------------------------------------------------------------------------------------------------------------------------------------------------------------------------------------------------------------------------	--------------------------------------------------------------------------------------------------------------------------------------------------------------------------------------------------------------------------------------------------------------------------------------------------------------------------------------------------------------------------------------------------------------------------------------------------------------------------------------------------------------------------------------------------------------------------------------------------------------------------------------------------------------------------------------------------------------------------

Ordering Information

Unit	Input	Output	Configuration	Options	Housing
PAC Ac Current Transducer	1A 0-1 amp 2A 0-2 amps 5A 0-5 amps 10A 0-10 amps 25A 0-25 amps	0-1MA into 10K Ω 0-20MA into 750 Ω (Available with 5A input only)	S Single Configuration T Triple Configuration	-50H 50Hz input frequency -400H 400Hz input frequency -CG Case ground terminal	SM Surface-mount housing DM DIN-rail mount housing
	0-90AC 0-150AC 0-300AC 0-600AC	0-1MA into 10K Ω			
PAV Ac Voltage Transducer	90-150AC 100-140AC 110-130AC 180-300AC 200-280AC 220-260AC	0-1MA into 10K Ω 4-20MA into 750 Ω 1-5V into 20K Ω	S Single Configuration		

Auxiliary-Powered Units

PAC Ac Current Transducer	1A 0-1 amp 2A 0-2 amps 5A 0-5 amps 10A 0-10 amps 25A 0-25 amps	4-20MA 1-5V	S Single Configuration	-50H 50Hz input frequency -400H 400Hz input frequency -120AC 85-150Vac auxiliary power (required for 4-20mA output with zero-based input) -240AC 170-300Vac auxiliary power (required for 4-20mA output with zero-based input) -CAL 25-125% calibration range -CG Case ground terminal	SM Surface-mount housing DM DIN-rail mount housing
	0-90AC 0-150AC 0-300AC 0-600AC	4-20MA 1-5V			

When ordering, specify: Unit / Input / Output / Configuration / Option [Housing]

Model number examples: PAC / 5A / 0-1MA / S / -50H [SM]

PAV / 0-150AC / 4-20MA / S / -120AC [SM]

PAC & PAV

Ac Current & Voltage Transducers

Figure 1. The PAC measures the amount of power used by a load device and transmits the data to a monitoring system.

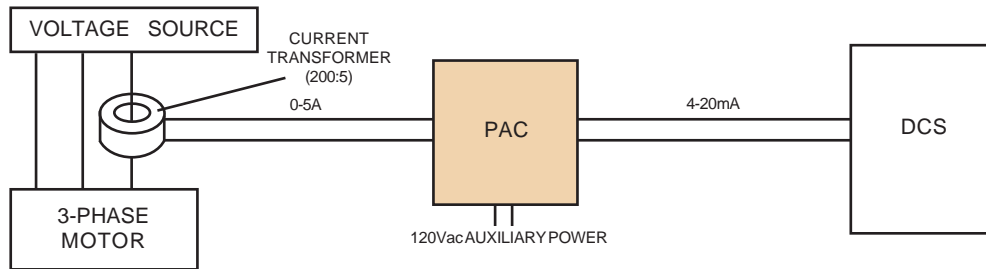

Figure 2. Triple configuration units are economical for monitoring the amount of electricity consumed by factory load devices.

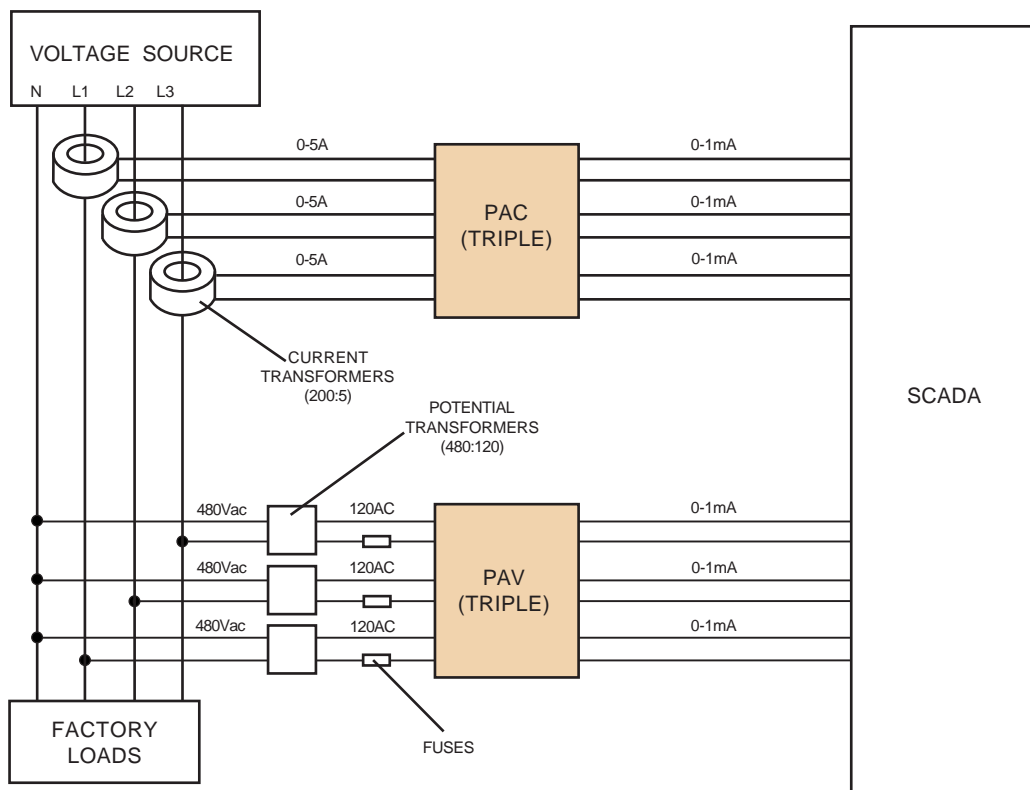
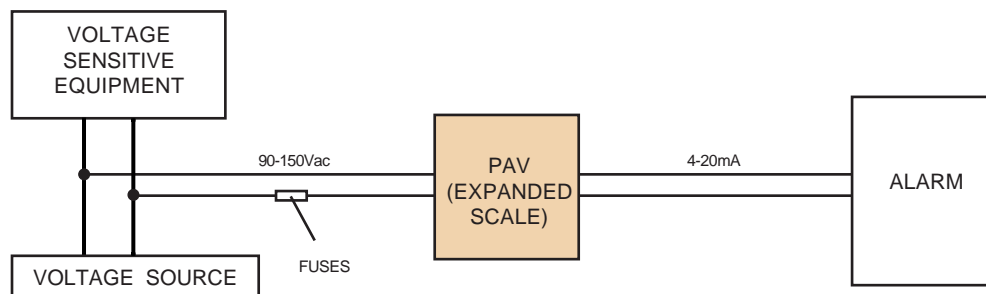

Figure 3. The PAC and PAV can be used to activate an alarm to avoid damage to voltage sensitive equipment.



PAC & PAV

Ac Current & Voltage Transducers

Figure 4. Terminal Designations.

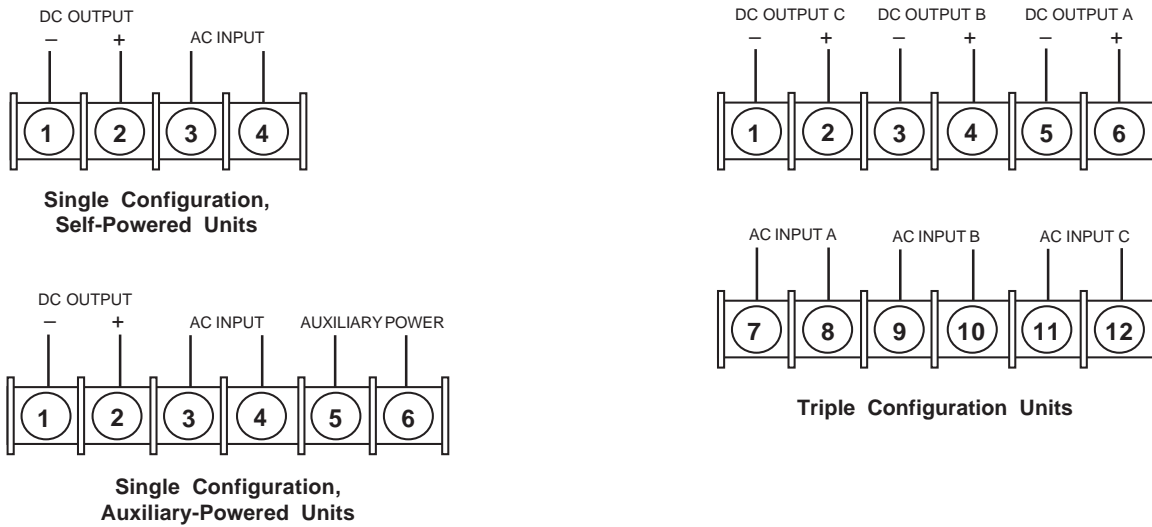
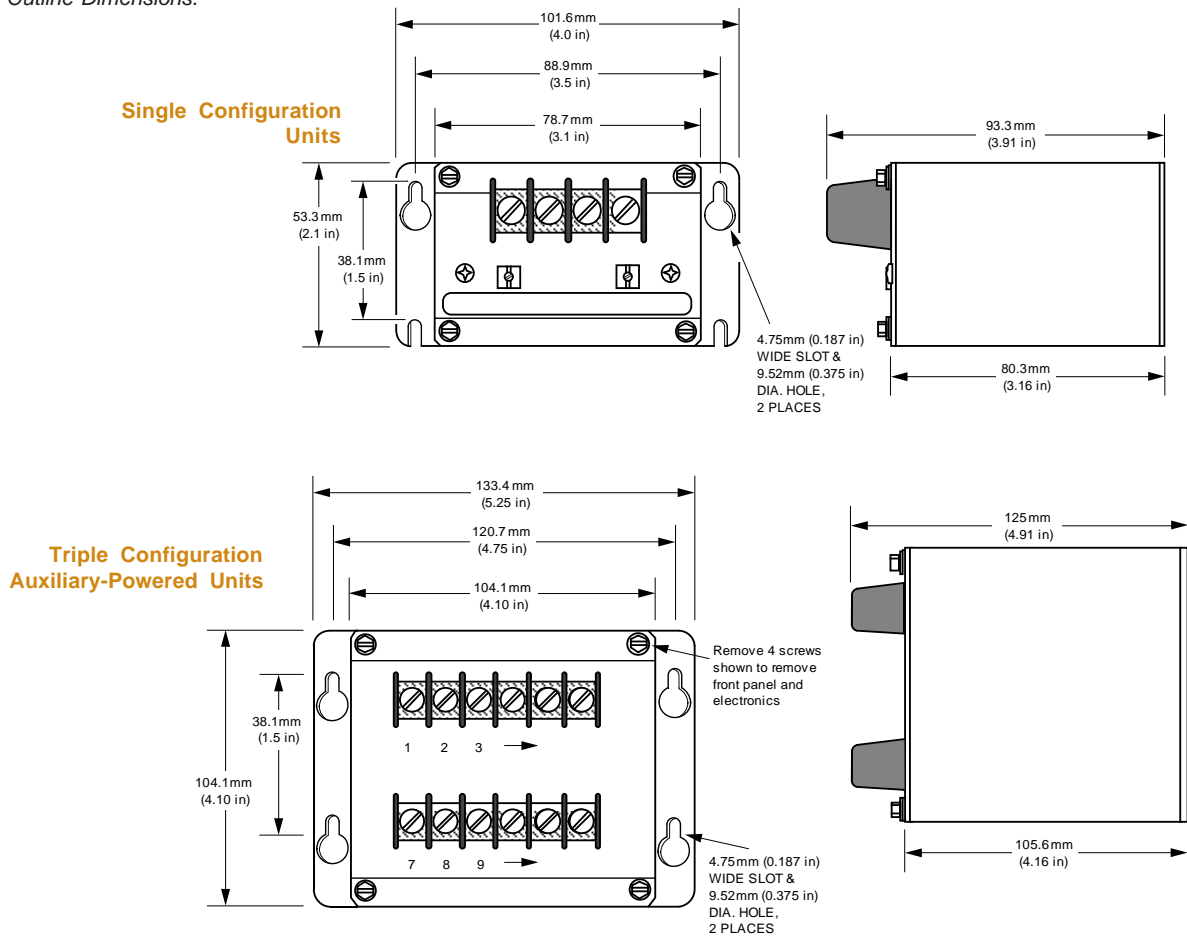

Figure 5. Outline Dimensions.



The Interface Solution Experts • www.miinet.com
 United States • info@miinet.com
 Tel: (818) 894-7111 • FAX: (818) 891-2816
 Australia • sales@mooreind.com.au
 Tel: (02) 8536-7200 • FAX: (02) 9525-7296

Belgium • info@mooreind.be
 Tel: 03/448.10.18 • FAX: 03/440.17.97
 The Netherlands • sales@mooreind.nl
 Tel: (0)344-617971 • FAX: (0)344-615920

China • sales@mooreind.com.cn
 Tel: 86-21-68406724 • FAX: 86-21-50623585
 United Kingdom • sales@mooreind.com
 Tel: 01293 514488 • FAX: 01293 536852