

## Description

Moore Industries' durable PIH Pressure-to-Current Transmitter provides an economical solution for any process that requires a rugged instrument capable of interfacing a pneumatic device with a data acquisition/control system, controller, recorder, or other electronic instrument.

This compact yet powerful unit accepts most pneumatic signals (3-15 psig, 0.2-1 bar, 3-27 psig, etc.) and accurately converts them to a proportional 4-20mA output.

The PIH is perfect for field mounting. Its metal casing makes it a tough field-mount unit when you need strength without the added expense of an explosion-proof enclosure.

Moore Industries also provides an entire selection of current-to-pressure converters, temperature transmitters, signal transmitters, alarms, signal isolators, and many other units for use with your PIH. Contact your Moore Industries representative or call the nearest Moore Industries facility for details.

**Figure 1.** The PIH converts a wide range of signals to a standard, 4-20mA isolated output.

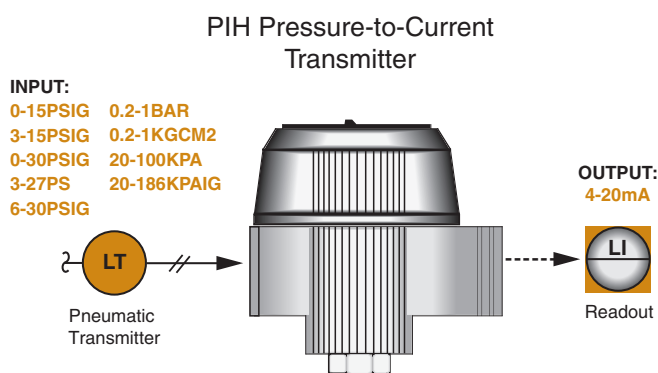

### Certifications



CE Conformant – EMC Directive 2004/108/EC  
EN61326



**Moore Industries' PIH** pressure-to-current transmitter is ideal for mounting in rugged field environments.

## Features

- Perfect for harsh field environments.**  
 Designed to be CE Conformant, the PIH is water tight, dust-tight, and resistant to corrosion and chemicals.
- Saves installation costs.**  
 Use the PIH to reduce costs by running electrical wiring instead of fragile and expensive pneumatic tubing from remote pneumatic devices.
- Immune to shock, vibration, and position.**  
 An advanced, high-technology sensor allows the PIH to perform with exceptional accuracy in unstable environments or unusual mounting positions.
- RFI/EMI protection.** Special circuit and housing designs protect against the harmful and unpredictable effects of radio frequency and electromagnetic interference.
- Reverse Output Option.** A special reverse output option sets the output to decrease proportionally as input increases, making the PIH a flexible choice for a variety of applications.

# PIH

Field-Mount  
Pressure-to-Current Transmitter

## Specifications

<p><b>Performance</b></p> <p><b>Calibration Capability:</b> ±0.2% of span including independent linearity as defined in SAMA Standard PMC 20.1–1973</p> <p><b>Repeatability:</b> Within ±0.1% of input span</p> <p><b>Resolution:</b> ±0.05% of input span</p> <p><b>Maximum Non-Linearity:</b> ±0.2% as per SAMA PMC 20.1–1973</p> <p><b>Load Capability:</b> 600 ohms at nominal 24Vdc</p> <p><b>Load Effect:</b> ±0.01% of span from zero to maximum load</p> <p><b>Pressure Limit:</b> 150% full scale input pressure without damage</p>	<p><b>Performance (continued)</b></p> <p><b>RFI/EMI Effect:</b> With field strengths of 30 V/m at frequencies of 20-1000MHz, less than ±0.2% span change when tested according to IEC 1000-4-3-1995</p> <p><b>Input:</b> Instrument air only</p> <p><b>Output Limit:</b> 130% of output span</p> <p><b>Output Ripple:</b> Negligible</p> <p><b>Line Voltage Effect:</b> Less than ±0.01% of span per volt of line voltage change at the input terminals</p> <p><b>Ambient Temperature Range:</b> –1°C to +54°C (+30°F to +129°F)</p> <p><b>Effect:</b> Less than ±2.0% of full scale input over above range</p>	<p><b>Connections</b> ½-inch NPT entry ports or M20 cable and ¼-inch NPT process connections.</p> <p><b>Adjustments</b></p> <p><b>Type:</b> Multiturn adjustments (no interaction between span and zero adjustments)</p> <p><b>Span:</b> Fully adjustable to 100% of output span</p> <p><b>Zero:</b> Adjusts 0 to ±10% of span</p> <p><b>Weight</b></p> <p><b>Metal Cover:</b> 808 grams (28.5 ounces)</p> <p><b>Polyester Cover:</b> 623.5 grams (22 ounces)</p>
--	---	---

## Ordering Information

Unit	Input	Output	Power	Options	Housing
PIH Field-Mount Pressure- to-Current Transmitter	0-15PSIG 3-15PSIG 0-30PSIG 3-27PSIG 6-30PSIG .2-1BAR .2-1KGCM2 20-100KPA 20-186KPA <small>(special ranges available, consult factory for specification changes)</small>	4-20MA	12-42DC	-RO Reverse Output, output decreases as input increases.	WDNS Aluminum body with black PBT polyester, Valox 357U cover; NPT pneumatic ports and ½-inch NPT female electrical entry port WDNA Aluminum body with aluminum cover (black polyurethane paint); NPT pneumatic ports and ½-inch NPT female electrical entry port WDMS Aluminum body with black PBT polyester, Valox 357U cover; NPT pneumatic ports and M20X1.5 (metric) female electrical entry port WDMA Aluminum body with aluminum cover (black solid polyurethane paint); NPT pneumatic ports and M20X1.5 (metric) female electrical entry port  <small>P suffix indicates enclosure comes equipped with base plate and U-bolts for mounting on a 2-inch pipe (i.e. WDNAP)</small>

**To order, specify:** Unit / Input / Output / Power / Options [Housing]  
**Model Number Example:** PIH / 3-15PSIG / 4-20MA / 12-42DC / -RO [WDMS]

Figure 2. Dimensions for the PIH

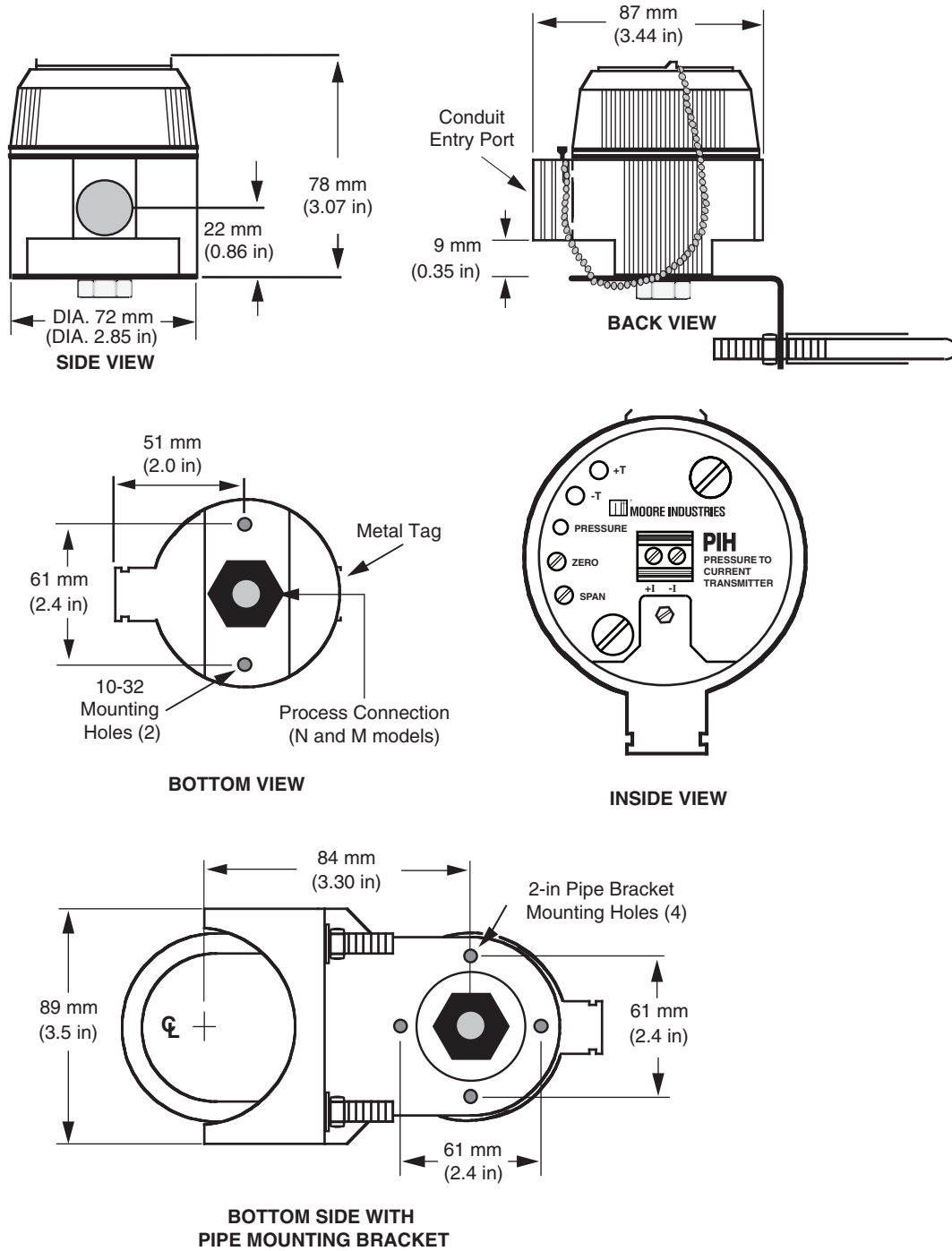

# PIH

Field-Mount  
Pressure-to-Current Transmitter



WORLDWIDE • [www.miinet.com](http://www.miinet.com)

United States • [info@miinet.com](mailto:info@miinet.com)  
Tel: (818) 894-7111 • FAX: (818) 891-2816  
Australia • [sales@mooreind.com.au](mailto:sales@mooreind.com.au)  
Tel: (02) 8536-7200 • FAX: (02) 9525-7296

Belgium • [info@mooreind.be](mailto:info@mooreind.be)  
Tel: 03/448.10.18 • FAX: 03/440.17.97  
The Netherlands • [sales@mooreind.nl](mailto:sales@mooreind.nl)  
Tel: (0)344-617971 • FAX: (0)344-615920

China • [sales@mooreind.sh.cn](mailto:sales@mooreind.sh.cn)  
Tel: 86-21-62491499 • FAX: 86-21-62490635  
United Kingdom • [sales@mooreind.com](mailto:sales@mooreind.com)  
Tel: 01293 514488 • FAX: 01293 536852