

New
Features!

Description

Moore Industries' SIY PC-Programmable Signal Isolator/Converter combines smart digital technology with advanced analog operation to deliver superior reliability, accuracy, and ease of use.

The highly versatile SIY programs to accept a wide range of current or voltage inputs. It outputs an isolated, proportional, 4-20mA signal. As a flexible analog/digital hybrid, this 2-wire (loop-powered) transmitter programs in seconds to handle a wide range of important signal interface applications:

- **Isolate Signals** to stop erratic process measurements caused by ground loops.
- **Convert Signals** so field instruments can interface directly with an indicator, recorder, DCS, PLC, or PC-based SCADA system.
- **Divert Signals** so the output from one transmitter can be sent to two separate locations.
- **Protect Equipment and Signals** by eliminating common electrical paths.
- **Boost Signals** so that more instruments can be added to an overburdened loop.
- **Solve "Bucking Power Supplies"** by stopping a conflict caused by a 4-wire transmitter and a DCS both trying to power the same process loop.

Figure 1. Compact yet powerful, this 2-wire signal interface features programmable inputs with a completely isolated output.

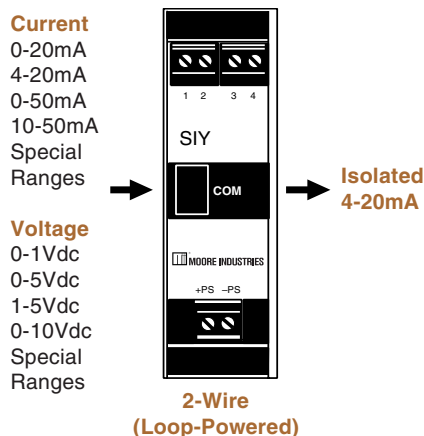

* All product names are trademarks of their respective companies.



Available in rail-mount DIN-style and head-mount "hockey-puck" housings, these precision instruments install in a high-density cabinet or in harsh field conditions.

Features

- **Wide range of signal input choices.** There's no need to specify and stock fixed-range instruments as spares. The SIY handles the majority of current/voltage interface applications you are likely to encounter.
- **Input/output opto isolation.** The SIY delivers superior protection against the harmful effects of ground loops and other plant "noise".
- **Fast measurement cycle.** Delivering an output update up to 8 times per second, you'll get analog speed combined with digital versatility.
- **RFI/EMI protection.** The SIY is resistant to the harmful, unpredictable effects of radio frequency and electromagnetic interference.
- **Enhanced configuration software.** From a single screen, you can set all the application-specific parameters. New features allow you to: trim input sensor readings, customize input linearization curves, program output damping, and calibrate other loop instruments—all from a single screen!

Certifications



Check the listing and the housing information on Page 3 for full certification details.

SIY

PC-Programmable
Signal Isolator/Converter

Specifications

<p>Performance Accuracy: $\pm 0.08\%$ of span (includes input accuracy, output accuracy, and the combined effects of linearity, hysteresis, repeatability, and adjustment resolution) Minimum Input Span: Current, 1mA; Voltage, 250mV Isolation: HPP housing, 1500Vrms input to output to case; DIN housing, 500Vrms input to output to case Measurement Cycle: Output updates 8 times per second Output Response: 256msec, maximum (128msec typical) for output to reach full scale in response to a 10-90% step change on input Input Impedance: Voltage, 1Mohm; Current, 20ohms Ripple: 10mV peak-to-peak maximum (measured across 250ohm resistor) Load Effect (current outputs): Negligible within specified load limits</p>	<p>Performance (continued) Power Supply Effect: 0.002% of span per 1V change Over-Voltage Protection: 48V, maximum on output; 48V reverse polarity protection on output Maximum Input Overrange: Current: 100mA maximum continuous; Voltage on Current Input: $\pm 5\text{Vdc}$ peak; Voltage: 18Vdc Load Capability: Supply Voltage - 10V = Ohms 21.4mA Output Current Limiting: 3.8mA (low) and 21.4mA (high) Operating Range: -40°C to $+85^{\circ}\text{C}$ (-40°F to $+185^{\circ}\text{F}$) Storage Range: -40°C to $+85^{\circ}\text{C}$ (-40°F to $+185^{\circ}\text{F}$) Effect of Ambient Temperature on Accuracy: $\pm 0.015\%$ of span/$^{\circ}\text{C}$ Relative Humidity: 0-95%, non-condensing</p> <p>Ambient Conditions</p>	<p>Ambient Conditions (continued) RF/EMI Immunity: 20V/m @ 20-1000MHz, when tested according to SAMA standard 33.1 (10V/m @ 80-1000MHz, 1kHz AM, when tested according to IEC 1000-4-3-1995) Common Mode Rejection: 100dB, minimum, @ 50/60Hz Normal Mode Rejection: 60dB, typical, @ 1V peak-to-peak, 50/60Hz</p> <p>Adjustments The choice of a current or a voltage input is selected via the input terminals; all other settings are made using Windows-based configuration software</p> <p>Weight HPP-Style Housing: 65 g (2.3 oz) DIN-Style Housing: 184 g (6.5 oz) LH1-Style Housing: Polyester Cover: 283.5 g (10 oz.) Metal Cover: 468 g (16.5 oz.)</p>
--	--	--

Stop Ground Loop Noise!

A difference in potential between a grounded transmitter and a grounded receiving device on the same loop may result in unpredictable ground loop problems, which can lead to signal drift.

Use the SIY to break the galvanic path between a field transmitter and an indicator, recorder, DCS, PLC, or PC-based SCADA system. This stops the harmful effects of ground loops, motor noise, and other electrical interferences.

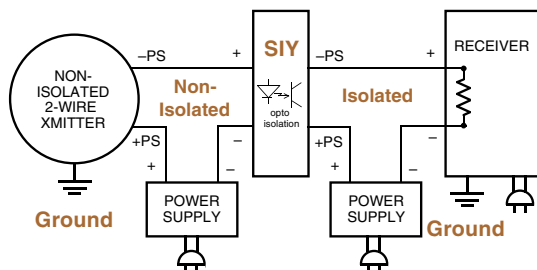

Everything you need is included...

Each SIY order comes with one copy of our Configuration Software on a 3½-inch floppy disk (Windows® 3.1, '95, '98, NT, 2000 and XP Compatible). To order additional copies, specify Moore Industries' part number: **235-75120-01**.

A SIY Configuration Cable is required to use the PC to configure the SIY. To order an unisolated cable for use in the shop using a grounded PC, specify Moore Industries part number **803-040-26**. If you plan to configure the SIY in the field or in areas with high ground potentials, specify part number **803-039-26** for a cable equipped with its own self-powered, input-to-output isolation circuit.

Ordering Information

Unit	Input	Output	Power	Options	Housing
SIY PC-Programmable Isolator/Converter	PRG Programmable with supplied Configuration Software and front panel connection terminals for: <u>CURRENT</u> (into 20ohms): Any range from -2.5mA to 55mA including: 0-20mA 4-20mA 0-50mA 10-50mA (recommended minimum span, 1mA) <u>VOLTAGE</u> (into 1Mohm): Any range from -0.5 to 11V including: 0-5Vdc 1-5Vdc 0-10Vdc (recommended minimum span, 250mV)	4-20mA Programmable output span between 4mA minimum and 20mA maximum into 650ohms with 24Vdc power supply	10-42DC 10-30DC Required for ISC, ISE, ISF, and NE options	-ISC CSA approved IS (HPP) -ISE LCIE-ATEX approved IS (HPP) -ISF FM approved IS (HPP) -NE Type N w/LH (HPP)	DIN DIN-style aluminum housing mounts on 32mm G-type (EN50035) and 35mm Top Hat (EN50022) rails HPP Hockey-puck housing for mounting in standard connection heads LH1NS Connection head (FM approved, NEMA 4X, IP66) with two entry ports: ½-inch NPT cable and process—black PBT polyester cover LH1MS Connection head (FM approved, NEMA 4X, IP66) with two entry ports: M20 cable and ½-inch NPT process—black PBT polyester cover LH1CS Connection head with two entry ports: M20 cable and ½ (BSP) process—black PBT polyester cover LH1NX Connection head with ½NPT entry and mounting plate for customer's air duct opening—black PBT polyester cover LH2NS‡ Explosion-proof connection head (FM approved, Class I, Div 1, Groups A*,B,C,D; Class II, Groups E,F,G; Class III) with two entry ports: ½-inch NPT cable and process—black metal cover LH2MS‡ Explosion-proof connection head (FM approved, Class I, Div 1, Groups A*,B,C,D; Class II, Groups E,F,G; Class III) with two entry ports: M20 cable and ½-inch NPT process—black metal cover CH6 Plastic connection head CH17 CSA & UL approved explosion-proof housing for use in Class I, Div 1, Groups A,B,C,D; Class II, Groups E,F,G; Class III NOTE: Add "E" suffix to any LH2 housing to obtain ATEX Flame-Proof certification. The 2-inch pipe mounting hardware is included. (e.g., LH2NSE) Add "P" suffix to any LH housing for 2-inch pipe mounting hardware. (e.g., LH1NSP) * For Group A (only) all conduits must be sealed within 18 inches. ‡ LH2 Explosion-proof certification carries 60°C (140°F) max ambient temperature restriction. Other connection heads, cabinets, and enclosures also available. Ask your Interface Solutions Expert for details.

When ordering, specify: Unit / Input / Output / Power / Options [Housing]

Model number example: SIY / PRG / 4-20MA / 10-42DC [DIN]

Certifications



Factory Mutual Approvals:

Intrinsically Safe & Non-Incendive [HPP]:

Class I, II, III, Division 1, Groups A, B, C, D, E, F, G
 Class I, Division 2, Groups A, B, C, D

Suitable for use in:

Class II, Division 2, Groups F and G
 Class III, Division 2

Temperature Code: T6@60°C Max. Op. Ambient

Explosion/Dust Ignition-Proof‡ [HPP in LH2]:

Class I, Division 1, Groups A*, B, C, D
 Class II and III, Division 1, Groups E, F, G
 T6@60°C Maximum Operating Ambient

Environmental Protection: NEMA 4X, IP66



Canadian Standards Association (CSA)

General (Ordinary) Location [DIN/HPP]

Intrinsically Safe & Non-Incendive [HPP]:

Class I, Divisions 1 and 2, Groups A, B, C, D



CENELEC/ATEX 94/9/EC Directive Approvals:

LCIE - Intrinsically Safe [HPP]

⊕ II 2G EEx ia IIC T6@60°C

ISSEp - Flame-Proof [HPP in LH2]

⊕ II 2GD EEx d IIC T6, IP66

Type N Inherent [LH] – ⊕ II 3G EEx nA II T6



CE Conformant – EMC Directive 89/336/EEC

EN 61326

* For Group A only, all conduits must be sealed within 18 inches

‡ 60°C (140°F) Maximum Operating Ambient Temperature

Convert Signals

The SIY takes one process signal type (such as 1-5V) and converts it to a standard, isolated 4-20mA. This allows devices like transmitters and transducers to interface directly with an indicator, recorder, DCS, PLC, or PC-based SCADA system.

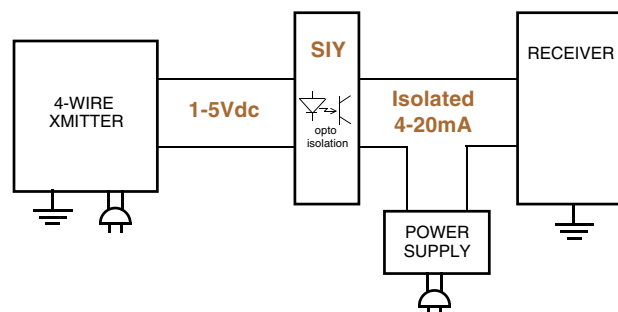

Divert and Protect Signals

Using the SIY, you can send the output from one transmitter to a second location, protect expensive monitoring/control equipment by eliminating common electrical paths, or create a buffer between devices to allow interruption of one system without impacting the other.

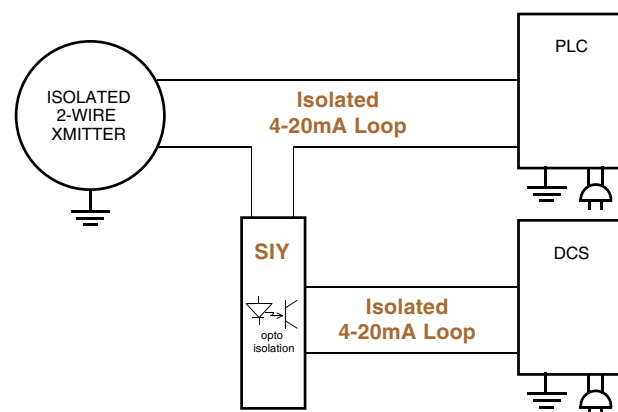

Boost Signals

If you need to add another instrument to an overloaded loop, use the SIY. It features a high drive capability of 650ohms (with a 24V power supply) and an input impedance of just 20ohms.

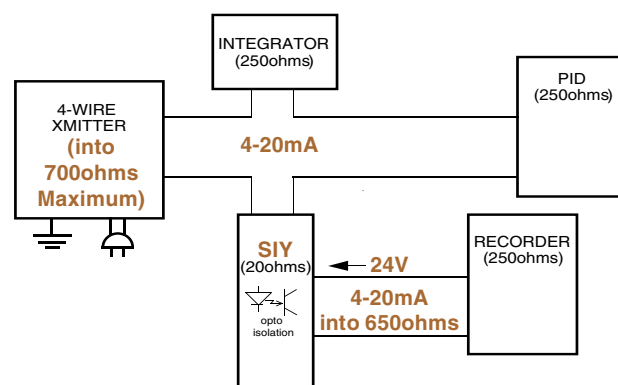

Solve "Bucking Power Supplies"

When two devices (such as a 4-wire transmitter and a DCS) are trying to source power to a loop, the result is a non-functioning loop. When neither of the devices can be eliminated, the solution is the SIY. It can operate with powered inputs from both sides, thus restoring normal operations to the loop.

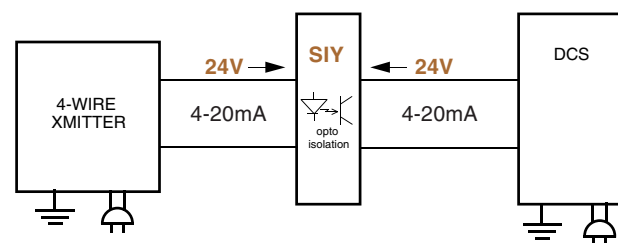

New Software!
New Features!

One Window. One Minute. One Setup.

Configuring the SIY is as simple as point-and-click. All you need is a PC running Windows (v3.1, '95, '98, or NT), our Configuration Software (one copy supplied free with each order), and a configuration cable. In minutes, you can begin configuring the following transmitter parameters:

- Input type and range (zero and full scale)
- Output range (4-20mA, zero and full scale)
- Noise rejection (50Hz or 60Hz)
- Direct or reverse output
- Over or under input range detection
- Custom instrument tag and serial number
- Custom input linearization
- Custom input trimming to actual sensors
- Fixed output with an easy loop test
- Damping time for erratic signal compensation (0-20.032 seconds)

Custom Linearization Tables—Unusual inputs are not a problem for the SIY. Not when it is so easy to build a custom 85-point linearization table with the Configuration Program's straightforward interface.

Output Damping—If your sensor is prone to step increases and decreases, use the SIY to lessen the impact on your process. You can program a damping value from 0 to 20.032 seconds, averaging out sensor fluctuations over the time period setting, and lessening the impact of step changes.

On-Screen Setup Confirmation—Once programmed, the operating parameters you have selected are constantly displayed in the configuration window.

Figure 2. From a single software window, you can program the SIY in one minute or less

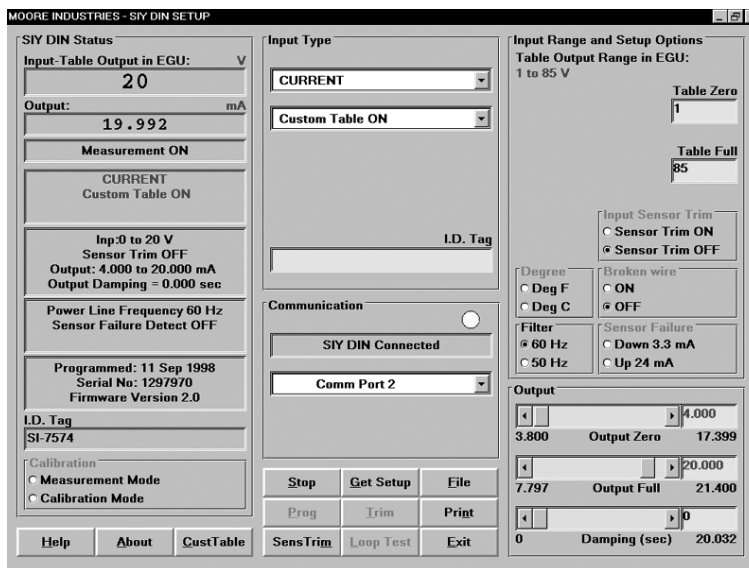

Configuration Alerts—Data fields on the configuration window provide alert messages (such as “Zero or Full Scale Outside of Conformance Range”) to let you know when you are making a nonstandard or ill-advised selection.

Store and Print Files—After you've created a configuration file, it can be downloaded to multiple SIY's, printed out as a hardcopy, or named and stored (on a PC hard drive or disk).

Reverse Output—Setting Zero Scale Input numerically above Full Scale Input will result in the transmitter's output going up when the input goes down, and vice-versa. When you have chosen this operation, the “Output” portion of the configuration screen changes to read “Reverse Output”.

Digital Output Trimming—A sophisticated yet simple-to-implement software feature allows you to adjust the SIY's output to compensate for inaccuracies in your readout equipment. The “Zero Scale Output” can be adjusted between 3.797 and 17.400mA. The “Full Scale Output” adjusts between 7.798 and 21.401mA.

Context-Sensitive HELP System—Just point to the area on the Configuration Screen where you are encountering difficulty, and an explanation appears on the bottom of the screen.

SIY

PC-Programmable Signal Isolator/Converter

Figure 3. Installation Dimensions.

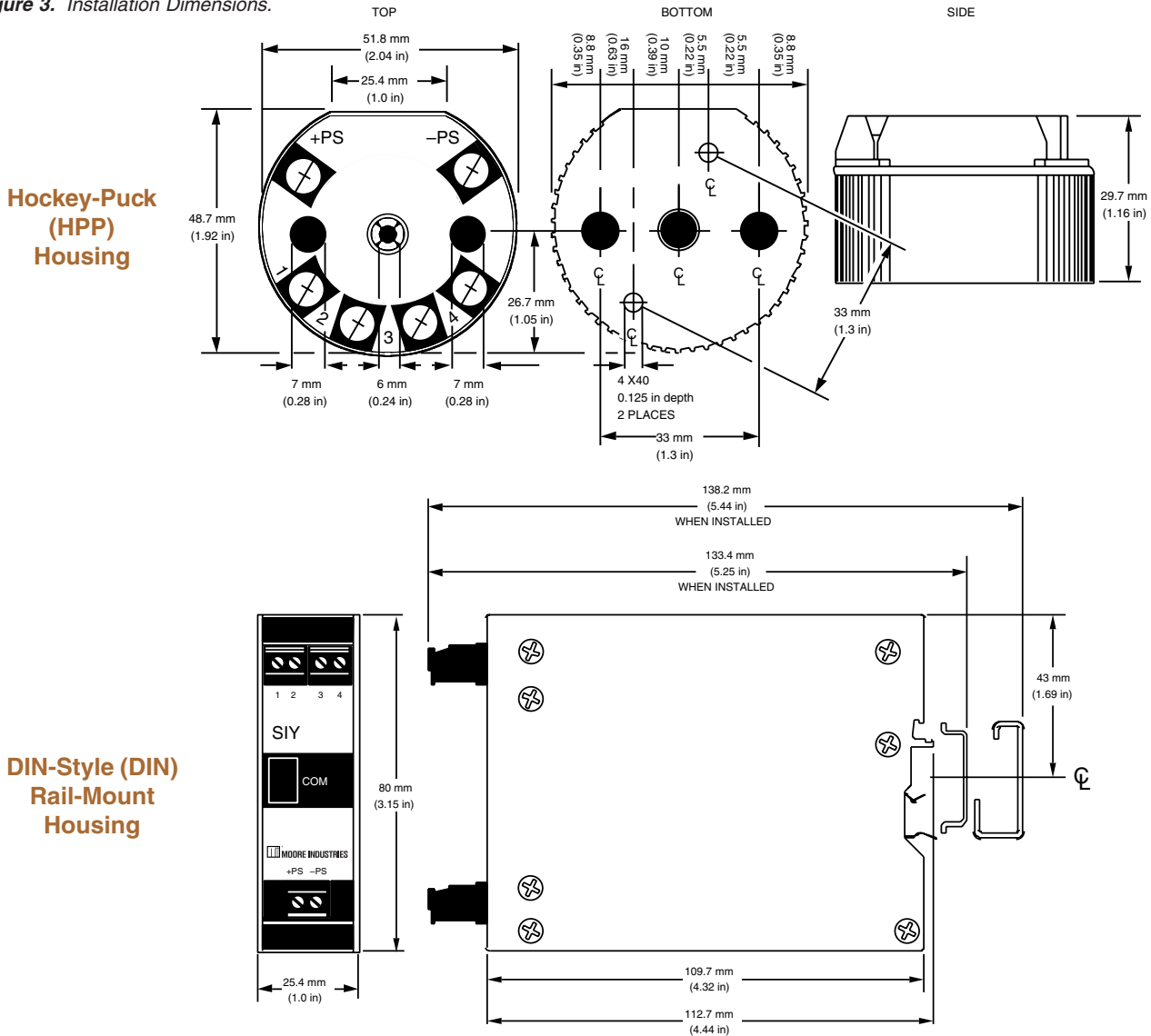

Table 1. Terminal Designations.

Input Type	Input Terminals				Output Terminals	
Terminal Number	1	2	3	4	Left to Right	
Current Inputs		+I		-I	+PS	-PS
Voltage Inputs			+V	-V	+PS	-PS

Factory Configuration Available

We can deliver your SIY PC-Programmable Isolator/Converters preconfigured to your specifications and ready to install.

You'll still receive a free copy of our software with your order so that you can reconfigure your SIY if your needs change. Consult your Moore Industries Sales Representative for details.



The Interface Solution Experts • www.miinet.com

United States • info@miinet.com
Tel: (818) 894-7111 • FAX: (818) 891-2816
Australia • sales@mooreind.com.au
Tel: (02) 8536-7200 • FAX: (02) 9525-7296

Belgium • info@mooreind.be
Tel: 03/448.10.18 • FAX: 03/440.17.97
The Netherlands • sales@mooreind.nl
Tel: (0)344-617971 • FAX: (0)344-615920

China • sales@mooreind.sh.cn
Tel: 86-21-62481120 • FAX: 86-21-62490635
United Kingdom • sales@mooreind.com
Tel: 01293 514488 • FAX: 01293 536852